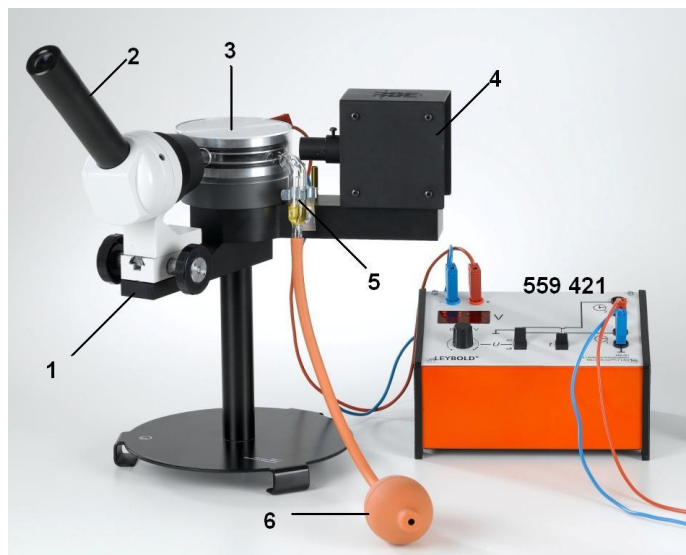

08/13-W07-Kem

**Instruction sheet 559 412****Millikan apparatus (559 412)**

- 1 Base plate
- 2 Measuring microscope with micrometer eyepiece
- 3 Plate capacitor
- 4 Illumination device
- 5 Oil atomizer
- 6 Rubber ball

**1 Description**

The Millikan apparatus is used to verify the quantization of the electrical charge and to determine the elementary charge by observing the motion of individually charged oil droplets in a homogenous electrical field.

The Millikan supply unit (559 421) is also needed for such experiments. It supplies the voltage for the plate capacitor and illumination device. Moreover, it also makes possible the connection of time measurement instruments and control of the experiment.

**2 Scope of delivery**

- 1 Base plate  
with measuring microscope and illumination device
- 1 Plate capacitor with acrylic glass cover
- 1 Oil atomizer (685 75)
- 1 Rubber ball (667 241)
- 1 Stand base
- 2 Adapters for safety plug
- 1 Oil, 50 ml (685 78)

**3 Technical data****Plate capacitor:**

Diameter:	8 cm
Distance between capacitor plates:	6 ( ±0.05 ) mm
Deviation from parallelism:	< 0.1 mm
Connection:	4-mm sockets

**Measuring microscope:**

Eyepiece magnification:	10
Objective magnification:	2 ( ±0.05 )
Length of micrometer scale:	10 mm
Scale graduation:	0.1 mm

**Illumination device:**

Halogen lamp (from 688 149):	12 V / 10 W
Lamp socket:	G4
Connection (to 559 421):	4-mm safety plugs

**Oil:**

Density:	877 kg m <sup>-3</sup> (at 15 °C) 871 kg m <sup>-3</sup> (at 25 °C)
----------	--

**General data:**

Stand rod:	12 mm dia
Height adjustment range:	13 cm
Dimensions:	25 cm × 30 cm × 45 cm
Weight:	4 kg

## 4 Components

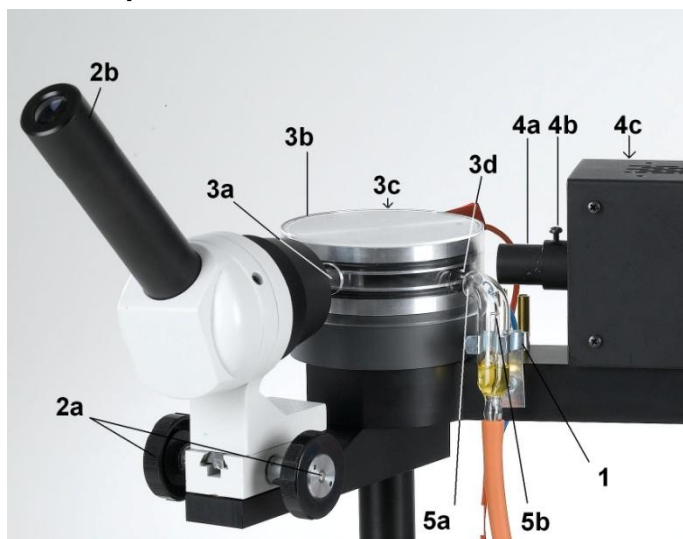

- 1 Base plate** with holder for oil atomizer pins for plate capacitor (1)
- 2 Measuring microscope**  
Knurled knobs (2a), micrometer eyepiece (2b)
- 3 Plate capacitor**  
Viewing window (3a), acrylic glass cover (3b), connecting sockets (3c), oil filling openings (3d)
- 4 Illumination device** with adjusting screws condenser (4a), fastening screw (4b), connecting sockets (4c)
- 5 Oil atomizer**  
Spray nozzle (5a), capillary tube (5b)

## 5 Putting into operation

### 5.1 Assembly:

- Fasten the base plate at the desired height in the stand base or, for example, into a bench clamp.
- Carefully place the acrylic glass cover over the sealing washers of the plate capacitor so that the corresponding holes are positioned over the connecting sockets.
- Lock the plate capacitor with viewing window onto the base plate oriented to the measuring microscope.
- Fill the oil atomizer with oil through the spray nozzle so that the bent capillary tube stands about 2 mm in the oil. Fit the oil atomizer into the holder making sure that the spray nozzle is positioned before the bore holes in the plastic cover.

### 5.2 Connecting to the Millikan supply unit:

- Connect the plate capacitor with the connector for plate capacitors on the Millikan supply unit (559 421) (if need be, use the adapters for the safety plug at the sockets of the plate capacitor).
- Connect the illumination device to the connector for illumination devices on the Millikan supply unit and turn on the illumination device.

### 5.3 Settings:

- Turn the lens holder of the micrometer eyepiece until you can clearly see the micrometer scale.
- If necessary, turn the eyepiece to orient the micrometer scale vertically. For this purpose you should slightly loosen the fastening screw.
- Use the knurled knob to push the measuring microscope close to the plastic cover.

The illuminated capacitor plates can be seen at the top and bottom in the circular-viewing field. The beginning and end of the micrometer scale are at a small distance to the capacitor plates.

To eliminate disturbing light reflex or to correct the observation space, if you are not satisfied with the illumination:

- Loosen the fastening screw of the capacitor and move the capacitor.
- You can also adjust the lamp with the help of the adjusting screw (recessed head screw).

### 5.4 Observing oil droplets

- Use the rubber ball to spray oil between the capacitor plates so that oil droplets can be seen in the entire observation field.
- By moving the measuring microscope with the help of the knurled knobs (2a), create a plane, in which a selected oil droplet is clearly seen as light point.

## 6 Objective magnification

Due to the objective magnification  $V$ , a fall or rise distance  $s$  of the oil droplet between the capacitor plates is represented on the scale section

$$x = V \cdot s$$

If the image of an oil droplet moves in the time  $\Delta t$  on the scale over a distance  $\Delta x$ , the velocity of the oil droplet is

$$v = \frac{\Delta x}{V \cdot \Delta t}$$

The objective magnification is  $V = 2$  quite accurately. For more exact measurements, you should determine the magnification:

- Remove the plate capacitor and put a suitable scale (for example glass scale 311 09) vertically on the base plate.
- Adjust the microscope so that external scale and micrometer scale can be clearly seen next to one another. By comparing the two scales, determine the exact magnification.

## 7 Maintenance

### 7.1 Cleaning plate capacitors:

Capacitor plates have been assembled with a great degree of parallelism.

- Do not disassemble capacitor plates.

Contact with alcohol leads to tears in the acrylic glass cover.

- Never use alcohol to clean the acrylic glass cover.

- Carefully remove the acrylic glass cover and use a cloth to clean the surface of the capacitor.
- If necessary, clear the two boreholes by blowing.

### 7.2 Replacing the halogen lamp:

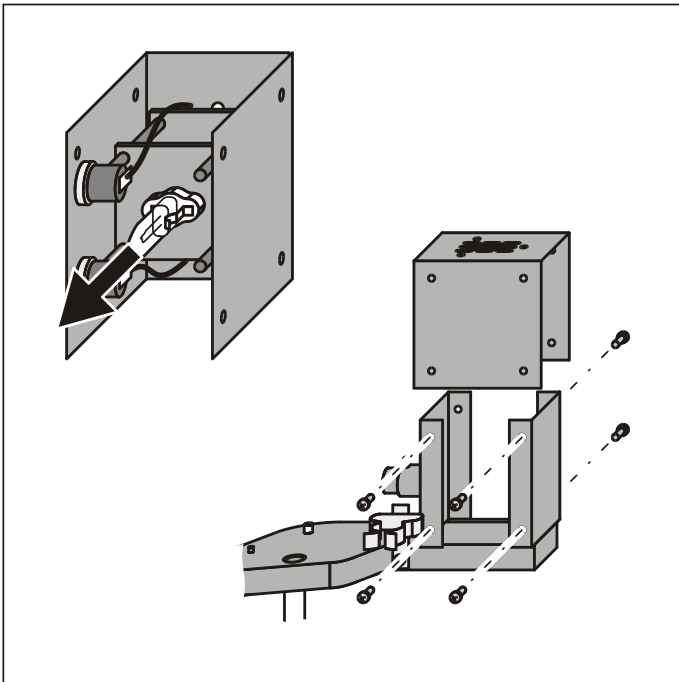

- Loosen the screws on the side of the illumination device and remove the cover.
- Take out the defective halogen lamp and put in a new lamp (do not touch the new halogen lamp with your fingers).
- Check the setting of the illumination device and, if necessary, use the adjusting screw to adjust the lamp.