

06/05-W97-Sel

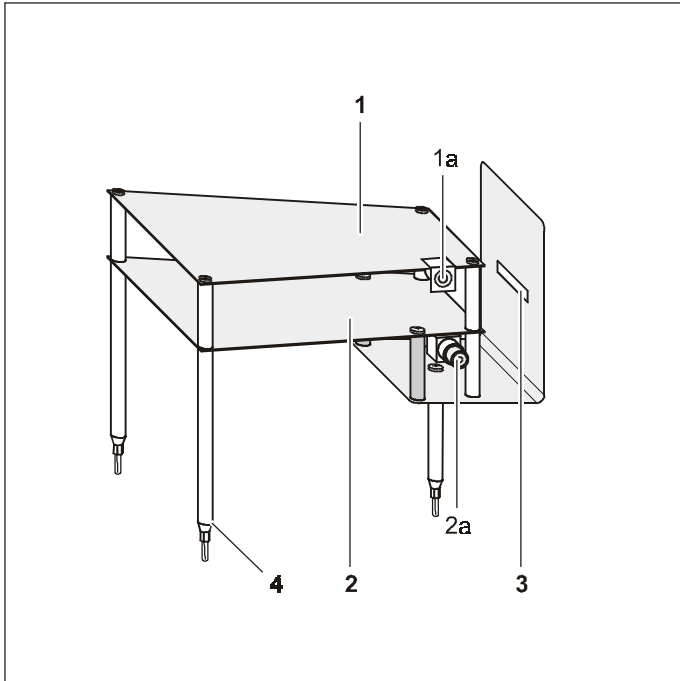

Instruction sheet 554 840

Plate Capacitor X-ray (554 840)

- 1 Top capacitor plate**
safety socket (1a)
- 2 Bottom capacitor plate**
BNC socket (2a)
- 3 Inlet diaphragm**
- 4 Mounting plugs, 4 mm**

1 Description

The plate capacitor is used to measure the ionization current of X-rays in the experiment chamber of the X-ray apparatus (554 81) and for determining the ion dose rate. The inlet diaphragm and the trapezoidal shape of the capacitor plates have been dimensioned so that the ionizing volume of the divergent X-ray radiation is completely within the bounds of the plate capacitor.

The top plate is connected to the positive pole of the high voltage via a safety socket, and the bottom plate is connected to a sensitive ammeter and to ground via a BNC lead.

2 Measuring the ion current

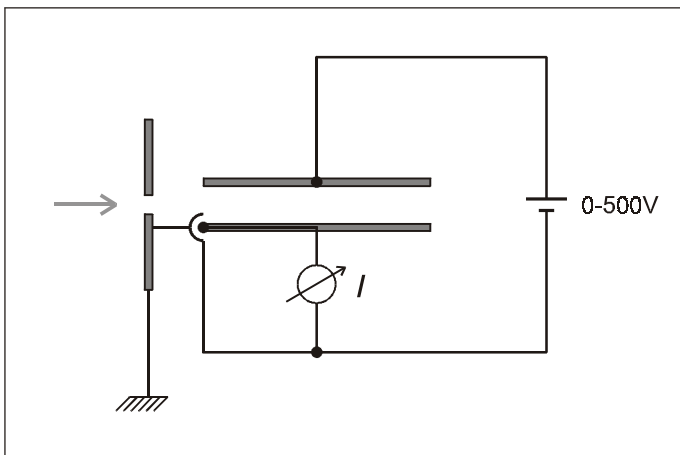

2 Technical data

Electrical data:

Input voltage:	max. 500 V DC
Saturation voltage:	approx. 100 V DC
Saturation current:	approx. 3×10^{-9} A

Electrical connections:

Top capacitor plate:	4-mm safety socket
Bottom capacitor plate:	BNC socket

Geometrical data:

Distance inlet diaphragm to focal spot of X-ray tube:	15.5 cm
Distance inlet diaphragm to capacitor plates:	2.5 cm
Plate width:	8.5 cm / 14 cm
Length of plates:	16 cm
Plate spacing:	3.5 cm
Inlet diaphragm:	4.5 cm × 0.6 cm
Ionizable air volume	125.4 cm ³

General data:

Dimensions:	19 cm × 14 cm × 17 cm
Weight:	600 g

4 Mounting the plate capacitor

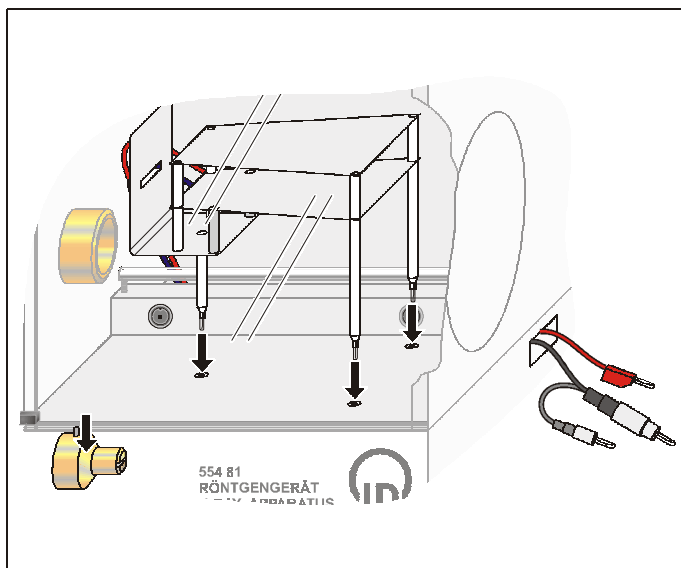

- Demount the goniometer (554 83) or the film holder X-ray (554 838) and the collimator of the X-ray apparatus if these are still mounted.
- Connect the adapter cable BNC/4 mm (575 24) to the BNC socket and a connecting lead to the high-voltage input of the plate capacitor.
- Lift the plate capacitor into the experiment chamber of the X-ray apparatus (554 81); insert the mounting plugs in the mounting sockets.
- Feed the two cables into the free channel until they reappear on the right side of the X-ray apparatus.

5 Carrying out the experiment

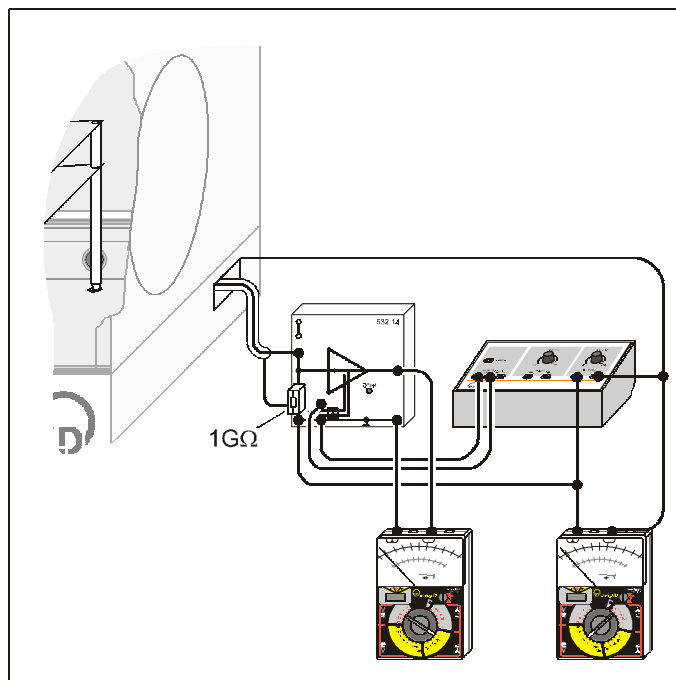

Recommended for power supply:

- | | |
|----------------|--------------|
| 1 Power supply | e.g. 522 27 |
| 1 Voltmeter | e.g. 531 120 |

Recommended for measuring current:

- | | |
|--------------------------|--------------|
| 1 Electrometer amplifier | 532 14 |
| 1 STE resistor 1 GΩ | 577 02 |
| 1 Voltmeter | e.g. 531 120 |
| 1 Adapter cable BNC/4 mm | 575 24 |