

Determining the density and mobility of charge carriers in p-germanium

Objects of the experiment

- Measuring of the Hall voltage as function of the current at a constant magnetic field: determination of the density and mobility of charge carriers.
- Measuring of the Hall voltage for as function of the magnetic field at a constant current:: determination of the Hall coefficient.
- Measuring of the Hall voltage as function of temperature: investigation of the transition from extrinsic to intrinsic conductivity.

Principles

The Hall effect is an important experimental method of investigation to determine the microscopic parameters of the charge transport in metals or doped semiconductors.

To investigate the Hall effect in this experiment a rectangular strip of p-doped germanium is placed in a uniform magnetic field B according Fig. 1. If a current I flows through the rectangular shaped sample an electrical voltage (Hall voltage) is set up perpendicular to the magnetic field B and the current I due to the Hall effect:

$$U_H = R_H \cdot \frac{I \cdot B}{d} \quad (I)$$

R_H is the Hall coefficient which depends on the material and the temperature. At equilibrium conditions (Fig. 1) for weak magnetic fields the Hall coefficient R_H can be expressed as function of the charge density (carrier concentration) and the mobility of electrons and holes:

$$R_H = \frac{1}{e_0} \cdot \frac{p \cdot \mu_p^2 - n \cdot \mu_n^2}{(p \cdot \mu_p + n \cdot \mu_n)^2} \quad (II)$$

$e_0 = 1.602 \cdot 10^{-19}$ As (elementary charge)

$p = p_E + p_S$ (total density of holes)

p_E : density of holes (intrinsic conduction)

p_S : density of holes (hole conduction due to p-doping)

$n = n_E$:density of electrons (intrinsic conduction)

μ_p :mobility of holes

μ_n mobility of electrons

From equation (II) follows: The polarity of predominant charge carriers can be determined from the Hall coefficient R_H if the directions of the current I and magnetic field B are known. The thinner the conducting strip the higher the Hall voltage.

The doping of group III elements like e.g. B, Al, In or Ga into the crystal lattice of germanium creates positive charged holes in the valence band (Fig. 2).

Fig. 1: Hall effect in a rectangular sample of thickness d , height b and length w : At equilibrium conditions the Lorentz force F_L acting on the moving charge carriers is balanced by the electrical force F_e which is due to the electric field of the Hall effect.

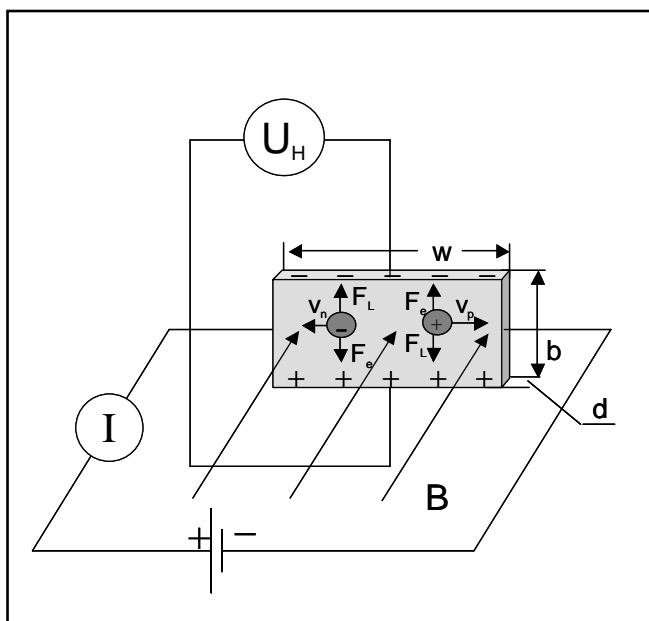

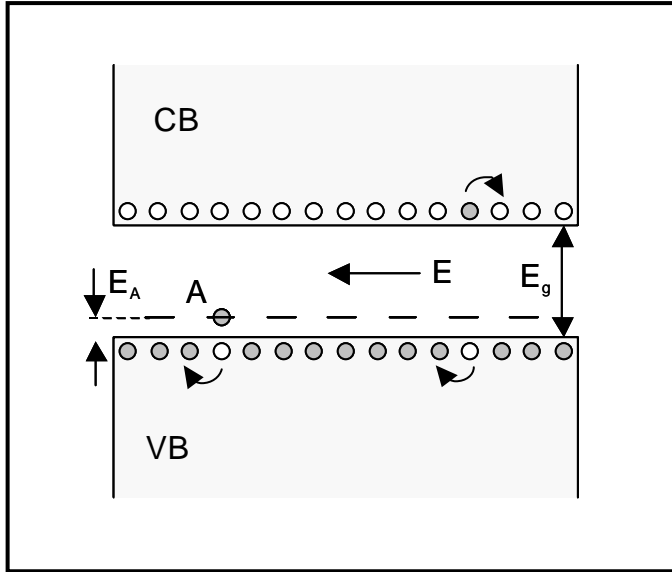

Fig. 2: Simplified diagram of extrinsic (left) and intrinsic conduction (right) under influence of an electric field E: Incorporating of dopants (acceptors A) into the crystal lattice creates positive charge carriers called holes in the valence band (VB). With increasing temperature the thermal energy of valence electrons increases allowing them to breach the energy gap E_g into the conduction band (CB) leaving a vacancy called hole in the VB.

Their activation energy E_A of about 0.01 eV is significantly smaller than the activation energy E_g (band gap) to generate electrons and holes by thermal activation (intrinsic charge carriers). At room temperatures in p-doped germanium the density of holes p_S can predominate the density of intrinsic charge carriers (p_E and n_E). In this case where the charge transport is predominately due to holes from the dopants ($n = n_E = p_E \approx 0$). The density of p_S can be determined by measuring the Hall voltage U_H as function of the current I. With equation (I) and (II) follows:

$$p_S = \frac{B}{e_0 \cdot d} \cdot \frac{I}{U_H} \quad (III)$$

The mobility is a measure of the interaction between the charge carriers and the crystal lattice. The mobility is defined as (in case p-doped germanium it is the mobility μ_P of the holes created by the dopants, i.e. acceptors):

$$\mu_P = \frac{v_P}{E} \quad (IV)$$

v_P : drift velocity

E: electric field due to the voltage drop

The electric field E can be determined by the voltage drop U and the length w of the p-doped germanium strip:

$$E = \frac{U}{w} \quad (V)$$

The drift velocity v_P can be determined from the equilibrium condition, where the Lorentz force compensates the electrical force which is due to the Hall field (Fig. 1)

$$e_0 \cdot v_d \cdot B = e_0 \cdot E_H \quad (VI)$$

which can be expressed using the relation $E_H = b \cdot U_H$ as

$$v_d = \frac{U_H}{b \cdot B} \quad (VII)$$

Substituting equation (V) and (VII) in equation (IV) the mobility μ_P of holes can be estimated at room temperatures as follows:

$$\mu_P = \frac{U_H \cdot w}{b \cdot B \cdot U} \quad (VIII)$$

The current I in a semiconductor crystal is made up of both hole currents and electron currents (Fig. 1):

$$I = b \cdot d \cdot (n_P \cdot \mu_P + n_n \cdot \mu_n) \quad (IX)$$

The carrier density depends on the dopant concentration and the temperature. Three different regions can be distinguished for p-doped germanium: At very low temperatures the excitation from electrons of the valence band into the acceptor levels is the only source of charge carriers. The density of holes p_S increases with temperature. It follows a region where the density p_S is independent of temperature as all acceptor levels are occupied (extrinsic conductivity). In this regime the charge transport due to intrinsic charge carriers can be neglected. A further increase in temperature leads to a direct thermal excitation of electrons from the valence band into the conduction band. The charge transport increases due to intrinsic conductivity and finally predominates (Fig. 2). These transition from pure extrinsic conduction to a predominately intrinsic conduction can be observed by measuring the Hall voltage U_H as function of the temperature.

To describe the Hall voltage as function of temperature U_H based on a simple theory equation (I) and (II) have to be extended in the following way:

It is assumed that the mobility of electrons and holes are different. Introducing the ratio of the mobility

$$k = \frac{\mu_n}{\mu_p} \quad (X)$$

equation (II) can be rewritten as follows:

$$R_H = \frac{1}{e_0} \cdot \frac{p - n \cdot k^2}{(p + n \cdot k)^2} \quad (XI)$$

For undoped semiconductors the temperature dependency of the charge carriers can be assumed as

$$n = n_0 \cdot e^{-\frac{E_g}{2k_B \cdot T}}$$

$$p = p_0 \cdot e^{-\frac{E_g}{2k_B \cdot T}} \quad (XII)$$

$k_B = 1.36 \cdot 10^{-23}$ J/K: Boltzmann constant

The product of the densities p and n is temperature dependent:

$$n \cdot p = n_E \cdot (p_E + p_S) = \eta^2 \quad (XIII)$$

where the effective state density η is approximated as

$$\eta^2 = N_0 \cdot e^{-\frac{E_g}{k_B \cdot T}} \quad (XIV)$$

In the extrinsic conductivity regime the density p_S of holes can be determined according equation (III). For the intrinsic charge carriers $p_E = n_E$ which leads to a quadratic equation for p_E with the solution:

$$p_E = -\frac{P_S}{2} + \sqrt{\frac{P_S^2}{4} + \eta^2} \quad (XV)$$

With equations (XI) and (XV) together with the relations $p = p_E + p_S$ and $n = n_E$ the temperature dependency of Hall voltage U_H can be simulated. Using for $E_g = 0.7$ eV the result of experiment P7.2.1.5 as estimate value for the simulation only two unknown parameters N_0 and k are left.

Apparatus

1 Base unit for Hall effect Ge.....	586 850
1 p-doped Ge plug-in board.....	586 852
1 Combi B-Sensor S.....	524 0381
1 Extension cable, 15-pole	501 11
1 Sensor CASSY	524 010
1 CASSY Lab	524 200
2 AC/DC Power supply 0 to 15 V, 5 A	521 501
1 DC Power Supply 0...16 V, 0...5 A.....	521 545
1 DC power supply	521 541
1 U-core with yoke.....	562 11
1 Pair of bored pole pieces.....	560 31
2 Coil with 250 turns.....	562 13
1 Stand rod, 25 cm	300 41
1 Leybold Multi clamp.....	301 01
1 Stand base, V-shape, 20 cm	300 02
7 Pair of cables, 1 m, red and blue	501 46

additionally required:

PC with Windows 95/98/NT or higher

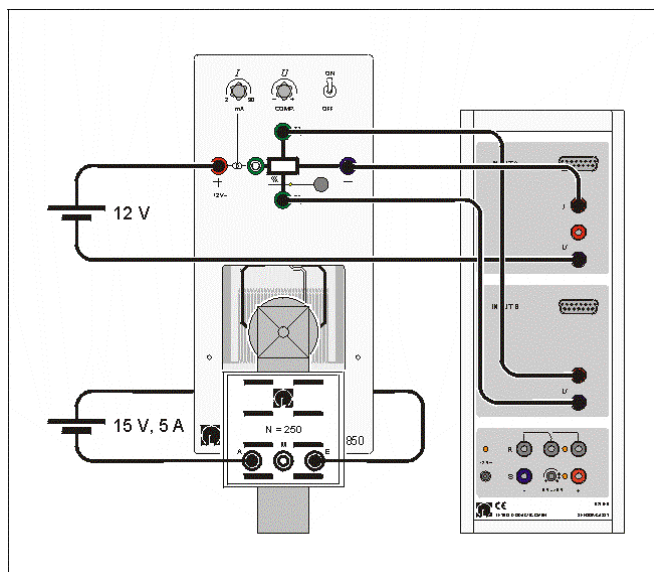

Fig. 2: Experimental setup (wiring diagram) for measuring the Hall voltage as function of the current I .

Setup**Mounting and connecting the plug-in board:**

- Insert the plug-in board with the p-doped Ge crystal into the DIN socket on the base unit for Hall effect until the pins engage in the holes.
- Carefully insert the plug-in board with DIN plug into the DIN socket on Insert the base unit with rod into the hole of the U-core all the way to the stop; make sure that the plug-in board is seated parallel to the U-core (see instruction sheet base unit Hall effect 586 850).
- Carefully attach the pair of bored pole pieces with additional pole piece, and slide the additional pole piece as far as the spacers of the plug-in boards (make sure that the plug-in board is not bent).
- Turn the current limiter of the current-controlled power supply to the left stop, and connect the power supply.

Safety notes

The n-doped Ge crystal is extremely fragile:

- Handle the plug-in board carefully and do not subject it to mechanical shocks or loads.

Due to its high specific resistance, the p-doped Ge crystal warms up even if only the cross-current is applied:

- Do not exceed the maximum cross-current $I = 33$ mA.
- Turn the control knob for the cross-current on the base unit for Hall effect to the left stop.

Measuring the magnetic field:

- The B-probe is fixed by the Stand rod to the V-shaped Stand base.
- Before the measuring the magnetic induction of the field B place the B-probe carefully in the gap (see instruction sheet base unit Hall effect 586 850) after the apparatus is adjusted.
- For the measurement connect B-probe to the Sensor CASSY using the extension cable.

Compensation of the Hall voltage:

- Before performing a measurement with a constant current I the Hall voltage have to be compensated for $B = 0$ T:
- 1. For measuring the current I connect the cables to the Input A of the Sensor CASSY (Fig. 3, see also instruction sheet base unit Hall effect 586 850).
- 2. For measuring the Hall voltage U_H connect the cables to the Input B of the Sensor CASSY (Fig. 3 see also instruction sheet base unit Hall effect 586 850).
- 3. Set the cross-current I to the maximum value (see instruction manual for n-doped Ge crystal 586 852), switch on the compensation and zero the Hall voltage U_H using the compensation knob.



Measuring the voltage drop:

- For measuring the voltage drop U connect the cables to the Input B of Sensor CASSY (see instruction sheet base unit Hall effect 586 850 measure the conductivity as function of temperature).
- Connect the cables to the Input A of the Sensor CASSY to measure the current I (see instruction sheet base unit Hall effect 586 850).
- Set the current I to the maximum value and measure the voltage drop U .



Measuring the temperature:

- For measuring the temperature ϑ connect the output signal of the heater to Input A of the Sensor CASSY (see instruction sheet base unit Hall effect 586 850 and Physics Leaflets P7.2.1.5.)

Carrying out the experiment**a) Measuring the Hall voltage as function of current**

- First compensate the Hall voltage (see above).
- Set the magnetic field B to a desired value and measure the magnetic flux density B (see above).
- Set the current to the maximum value and measure the voltage drop U .
- Measure the Hall voltage U_H (Input B on Sensor CASSY) as function of the current I (Input A on Sensor CASSY).
- After connecting the cables set the parameters with .
- For measuring use the button  or F9 in manual measuring mode.
- Save your measurement .

b) Measuring the Hall voltage as function of magnetic field

- First compensate the Hall voltage (see above).
- Set the current I to a desired value.
- Measure the Hall voltage U_H (Input B on Sensor CASSY) as function of the magnetic field B (Input A on Sensor CASSY).
- After connecting the cables set the parameters with .
- For measuring use the button  or F9 in manual measuring mode.
- Save your measurement .

c) Measuring the Hall voltage as function of temperature

- First compensate the Hall voltage U_H (see above) and set the current I to a desired value.
- Set the magnetic field B to a desired value (see above).
- Measure the Hall voltage U_H (Input B on Sensor CASSY) as function of the Temperature ϑ (Input A on Sensor CASSY, see above).

Measuring example**a) Measuring the Hall voltage as function of current**

Fig. 4: Hall voltage U_H as function of the current I for different magnetic fields. The straight lines correspond to a fit according equation (I).

current: $I = 30 \text{ mA}$

voltage drop: $U = 1,4 \text{ V}$.

b) Measuring the Hall voltage as function of magnetic field

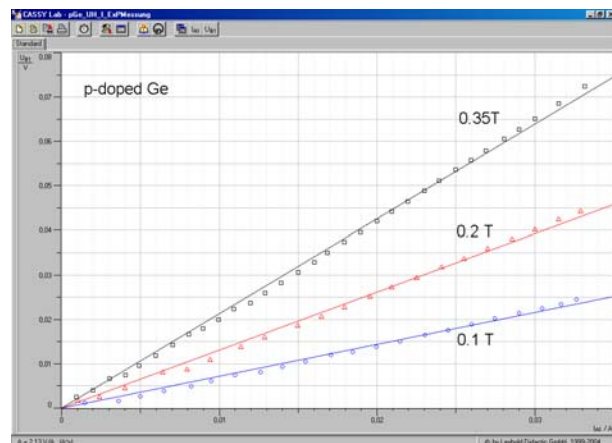
Fig. 5: Hall voltage U_H as function of the magnetic field B for $I = 30 \text{ mA}$. The straight line with slope A corresponds to a fit according equation (I).

c) Measuring the Hall voltage as function of temperature

Fig. 6: Hall voltage U_H as function of the temperature T for $I = 30 \text{ mA}$ and different magnetic fields B .

Evaluation and results

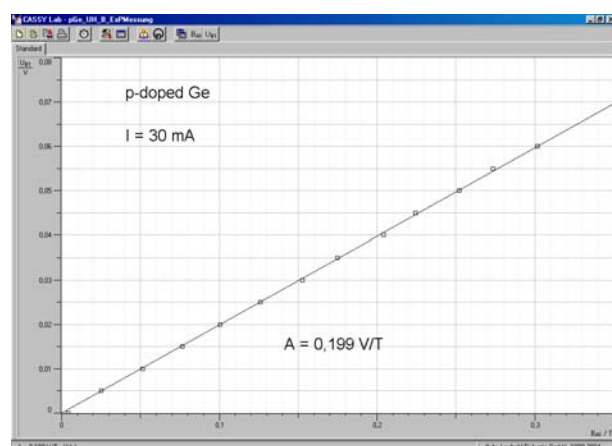
a) Measuring the Hall voltage as function of current

For the measurement with e. g. $B = 0,35 \text{ T}$ and $I = 30 \text{ mA}$ in Fig. 4 the slope

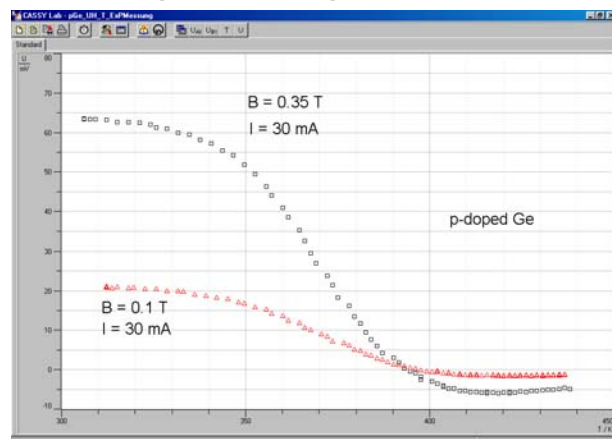
$$A = \frac{R_H \cdot B}{d} = 2.13 \frac{\text{V}}{\text{A}}$$

is obtained by the fitting a straight line through the origin (right mouse click in the diagram and "fit function"). With the linear regression result and equation (III) the density p_S of holes in the extrinsic conducting regime can be determined as follows:

$$d = 1 \cdot 10^{-3} \text{ m}$$

$$B = 0.35 \text{ T}$$

$$p_S = \frac{B}{e_0 \cdot d \cdot A} = 1.1 \cdot 10^{21} \frac{1}{\text{m}^3}$$

With the experimental results at room temperature

$$U = 1.4 \text{ V}$$

$$B = 0.35 \text{ T}$$

$$U_H = 72 \text{ mV}$$

and the dimensions of the p-doped germanium strip

$$b = 10 \text{ mm}$$

$$w = 20 \text{ mm}$$

the drift velocity v_p (equation (VII)) and the mobility μ_p (equation (VIII)) of the charge carriers in the extrinsic region can be estimated:

$$v_p = \frac{U_H}{b \cdot B} = 21 \frac{\text{m}}{\text{s}}$$

$$\mu_p = \frac{U_H \cdot w}{b \cdot B \cdot U} = 2940 \frac{\text{cm}^2}{\text{Vs}}$$

b) Measuring the Hall voltage as function of magnetic field

As can be seen from the linear regression of a straight line through the origin the Hall voltage U_H is proportional to the magnetic field B :

$$U_H \sim B.$$

Together with the result of part 1., i.e. $U_H \sim I$, the following relation is found:

$$U_H \sim I \cdot B.$$

Thus the theoretically derived formula (equation (I)) for the Hall voltage U_H of a strip-shaped conductor of thickness d is confirmed. Form the fit of a straight line to the experimental data of Fig. 5 the Hall coefficient R_H is obtained as follows:

$$d = 1 \cdot 10^{-3} \text{ m}$$

$$I = 30 \text{ mA}$$

$$A = 0.199 \text{ V/T (slope of Fig. 5)}$$

$$R_H = \frac{A \cdot d}{I} = 6.6 \cdot 10^{-3} \frac{\text{m}^3}{\text{As}}$$

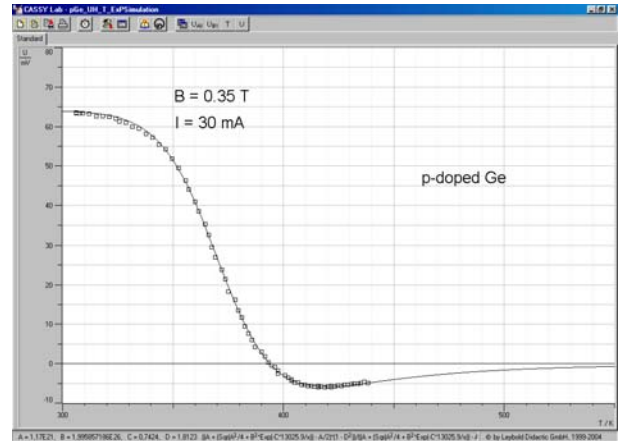

Fig. 7: Fit according equation (XVI) to the experimental data of Fig 6 for $B = 0.35 \text{ T}$ and $I = 30 \text{ mA}$.

A comparison with e. g. the Hall coefficient of the metallic conductor silver ($R_H = 8.9 \cdot 10^{-11} \text{ m}^3 \text{ C}^{-1}$ experiment P7.2.1.1) shows that the Hall coefficient is about 10^7 larger for semiconductors.

c) Measuring the Hall voltage as function of temperature

Using equations (XI) and (XV) together with the relations $p = p_E + p_S$ and $n = n_E$ the Hall voltage U_H can be expressed as follows:

$$U_H = \frac{((A + (\text{Sqr}(A^2/4 + B^2 \cdot \text{Exp}(-C \cdot 13025.9/x)) - A/2) \cdot (1 - D^2)) / ((A + (\text{Sqr}(A^2/4 + B^2 \cdot \text{Exp}(-C \cdot 13025.9/x)) - A/2) \cdot (1 + D))^2) \cdot 7.49 \cdot 10^{22}}{(XVI)}$$

Using equation (XVI) the temperature behavior of the Hall voltage U_H can be simulated with the following fit parameters (For performing a Fit with CASSY Lab use key Alt F):

$$A = 1.17 \cdot 10^{21} \text{ m}^{-3}$$

$$B = N_0 = 1.99 \cdot 10^{26} \text{ m}^{-3}$$

$$C = E_g = 0.74 \text{ eV}$$

$$D = \mu_n / \mu_p = 1.81$$

The result of the fit is shown in Fig. 7.

The temperature dependency of the Hall voltage U_H probes the transition from a charge transport due to holes to a bipolar charge transport of electrons and holes. At room temperatures the observed behavior of U_H is due to holes created by the acceptor atoms in the germanium lattice. Increasing the temperature, the charge transport is more and more due to thermally activated electrons and "vacancies" left in the valence band. When the number of the "faster" electrons exceeds the number of holes the Hall voltage U_H becomes negative. According equation (II) a sign change of U_H takes place when

$$p \cdot \mu_p^2 = n \cdot \mu_n^2.$$

The negative temperature range of the Hall voltage is determined by the electrons. Their drift velocity and thus their mobility is larger as the drift velocity and mobility of the holes, respectively.

$$\mu_n \approx 2 \cdot \mu_p$$

At high temperatures the charge density of holes and electrons are approximately the same. The Hall voltage U_H approaches finally zero due to the equal but opposite electrical fields of the electrons and holes (Fig. 7). For that reason no Hall Effect can be observed in pure semiconductors (intrinsic charge carriers only).

The simplified model neglects corrections of the quantum theory, i.e. band structure and effective mass. Especially, the effective state density N_0 is not constant as assumed in equation (XIV). N_0 has to be replaced by the product of the effective state densities of the conduction band N_C and valence band N_V :

$$N_0 = N_C \cdot N_V \propto T^{\frac{3}{2}} \quad (\text{XII})$$

Supplementary information

The Hall effect was discovered in 1879. Although the Hall effect is present in all conducting materials it remained a laboratory curiosity until the later half of 2000 century. With the advent of semiconductor technology and development of various III- and V-compounds it has become possible to produce Hall voltages several orders of magnitude larger than with earlier materials. In technical applications the Hall effect of semiconductors is especially used in magnetic measurement probes.