

Investigating the relationship between the coefficient of attenuation and the atomic number Z

Objects of the experiment

- To measure the transmittance T for x-rays as a function of the atomic number Z at a fixed wavelength outside of the absorption edges.
- To investigate the Z -dependency of the attenuation coefficient μ outside of the absorption edges.
- To confirm the Z^4 law as a function of the absorption coefficient τ .

Principles

The attenuation of x-rays when passing through matter is caused by both absorption and scattering. The linear attenuation coefficient μ is thus composed of the linear absorption coefficient τ and the linear scattering coefficient σ .

$$\mu = \tau + \sigma \quad (I)$$

These coefficients are proportional to the mass and the density ρ of the transilluminated material respectively. That is why we often use the so-called mass coefficients

$$\mu_m = \frac{\mu}{\rho}, \tau_m = \frac{\tau}{\rho}, \sigma_m = \frac{\sigma}{\rho} \quad (II)$$

or – for the pure metals observed here – the atomic coefficients or cross-sections

$$\mu_a = \mu_m \frac{A}{N_A}, \tau_a = \tau_m \frac{A}{N_A}, \sigma_a = \sigma_m \frac{A}{N_A} \quad (III)$$

A: atomic weight

$N_A = 6,022 \cdot 10^{23} \frac{1}{\text{mol}}$: Avogadro's number

Analogously to equation (I), we can say that

$$\mu_m = \tau_m + \sigma_m \quad (IV)$$

and

$$\mu_a = \tau_a + \sigma_a \quad (V)$$

The absorption of x-rays is essentially due to the ionization of atoms, which release an electron from an inner shell. Consequently, the absorption cross-section τ_a is heavily dependent on the excitation energy of the atoms and thus on the atomic number Z (see Fig. 1). Outside of the absorption edges, at which the quantum energy $h\nu$ of the x-rays just corresponds to the binding energy E of the electrons, the monochromatic x-ray radiation at a fixed wavelength λ is described to within a close approximation by the relationship

$$\tau_a = C_2 \cdot Z^4 \quad (VI)$$

The experiment confirms this relationship by means of transmittance measurements on the metals Al, Fe, Cu, Zr and Ag at the wavelength $\lambda = 40 \text{ pm}$, which is below the absorption edges of these elements (see table 1).

Tab. 1: Atomic number Z of the metals under study and absorption edge λ_K of K shell [1]

Element	Z	$\frac{\lambda_K}{\text{pm}}$
Al	13	796.7
Fe	26	174.3
Cu	29	138.1
Zr	40	68.9
Ag	47	48.6

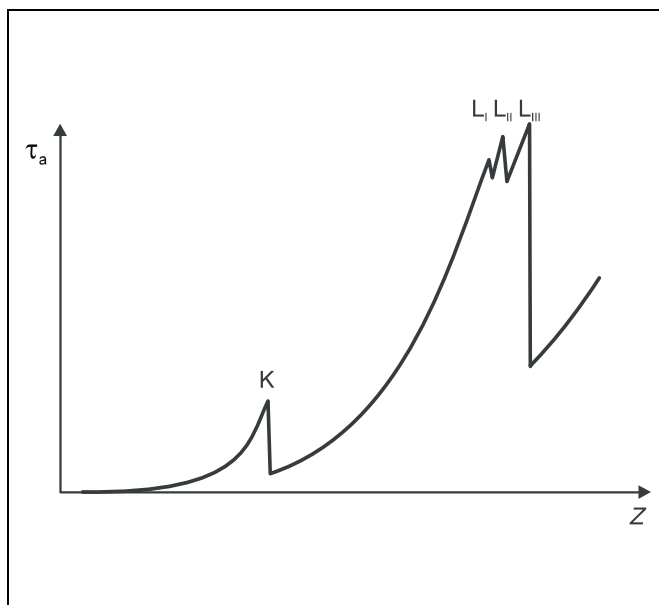

Fig. 1 Absorption coefficient as a function of the atomic number at a fixed x-ray wavelength (Schematic)
K: absorption edge of K shell
 L_I, L_{II}, L_{III} : absorption edges of L shell

Apparatus

1 X-ray apparatus	554 811
1 End-window counter for α , β , γ and x-ray radiation	559 01
1 Set of absorber foils	554 832

The evaluation exploits the fact that the scattering cross-section σ_a at the selected wavelength is significantly less than the absorption cross-section and can be estimated approximately using

$$\sigma_a = 0.2 \frac{\text{cm}^2}{\text{g}} \cdot \frac{A}{N_A} \tag{VII}$$

By applying a series of transformations to equations (III)-(VII), we obtain the following equation for determining the absorption cross-section:

$$\tau_a = \frac{\mu}{\rho} \cdot \frac{A}{N_A} - 0.2 \frac{\text{cm}^2}{\text{g}} \cdot \frac{A}{N_A} \tag{VIII}$$

This experiment measures the transmittance

$$T = \frac{R}{R_0} \tag{IX}$$

R_0 : counting rate in front of attenuator

R : counting rate behind attenuator

of the transilluminated material at a fixed x-ray wavelength λ . When we apply Lambert's law

$$T = e^{-\mu x} \tag{X}$$

x : thickness of attenuator

we can calculate the linear attenuation coefficient μ and, using this value and equation (VIII), the absorption cross-section τ_a :

$$\tau_a = \frac{-\ln T}{\rho \cdot x} \cdot \frac{A}{N_A} - 0.2 \frac{\text{cm}^2}{\text{g}} \cdot \frac{A}{N_A} \tag{XI}$$

Safety notes

The x-ray apparatus fulfills all regulations governing an x-ray apparatus and fully protected device for instructional use and is type approved for school use in Germany (NW 807/97 Rö).

The built-in protection and screening measures reduce the local dose rate outside of the x-ray apparatus to less than $1 \mu\text{Sv/h}$, a value which is on the order of magnitude of the natural background radiation.

- Before putting the x-ray apparatus into operation inspect it for damage and to make sure that the high voltage is shut off when the sliding doors are opened (see Instruction Sheet for x-ray apparatus).
- Keep the x-ray apparatus secure from access by unauthorized persons.

Do not allow the anode of the x-ray tube Mo to overheat.

- When switching on the x-ray apparatus, check to make sure that the ventilator in the tube chamber is turning.

The goniometer is positioned solely by electric stepper motors.

- Do not block the target arm and sensor arm of the goniometer and do not use force to move them.

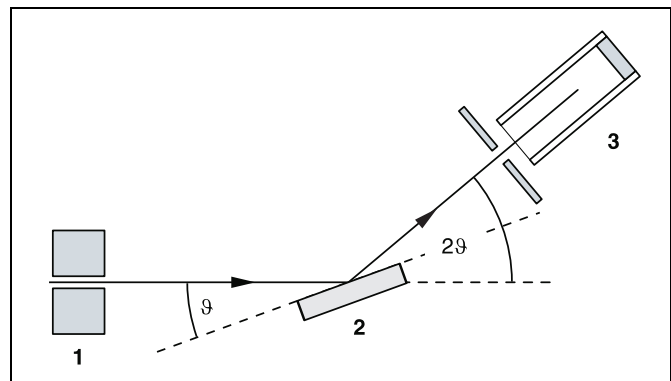

Fig. 2 Diffraction of x-rays at a monocrystal and for 2ϑ coupling between counter-tube angle and scattering angle (glancing angle)
1 collimator, 2 monocrystal, 3 counter tube

A goniometer with NaCl crystal and a Geiger-Müller counter tube in the Bragg configuration are used to select the wavelength. The crystal and counter tube are pivoted with respect to the incident x-ray beam in 2ϑ coupling, i.e. the counter tube is turned at an angle twice as large as the crystal (see Fig. 2).

In accordance with Bragg's law of reflection, the scattering angle ϑ in the first order of diffraction corresponds to the wavelength

$$\lambda = 2 \cdot d \cdot \sin \vartheta \tag{XII}$$

$d = 282.01 \text{ pm}$: lattice plane spacing of NaCl

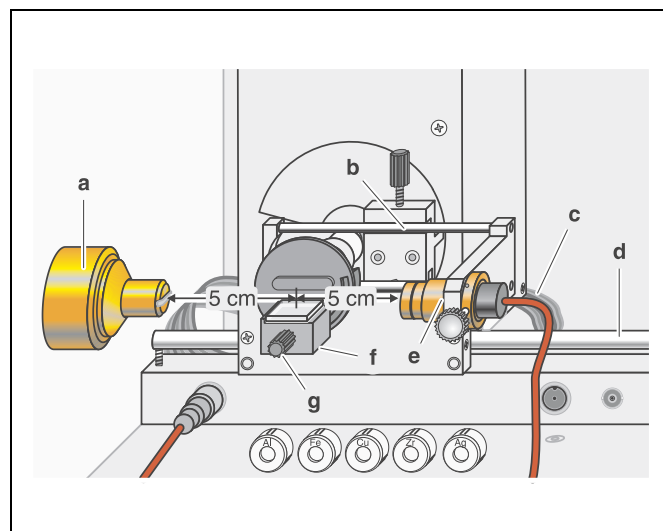

Fig. 3 Experiment setup for investigating the dependence of the coefficient of attenuation on the atomic number

Setup

Setup in Bragg configuration:

Set up the experiment as shown in Fig. 3. To do this, proceed as follows (see also the Instruction Sheet for the x-ray apparatus):

- Mount the collimator in the collimator mount (a) (note the guide groove).
- Attach the goniometer to guide rods (d) so that the distance s_1 between the slit diaphragm of the collimator and the target arm is approx. 5 cm. Connect ribbon cable (c) for controlling the goniometer.
- Remove the protective cap of the end-window counter, place the end-window counter in sensor seat (e) and connect the counter tube cable to the socket marked GM TUBE.
- By moving the sensor holder (b), set the distance s_2 between the target arm and the slit diaphragm of the sensor receptor to approx. 5 cm.
- Mount the target holder with target stage.
- Loosen knurled screw (g), place the NaCl crystal flat on the target stage (f), carefully raise the target stage with crystal all the way to the stop and carefully tighten the knurled screw (prevent skewing of the crystal by applying a slight pressure).
- If necessary, adjust the mechanical zero position of the goniometer (see Instruction Sheet for x-ray apparatus).

Note:

NaCl crystals are hygroscopic and extremely fragile.

Store the crystals in a dry place; avoid mechanical stresses on the crystal; handle the crystal by the short faces only.

Carrying out the experiment

The counting rates should not be greater than 600 pulses/s, so that it is not necessary to correct for dead time.

- Set the tube high voltage $U = 35.0$ kV and the emission current $I = 0.60$ mA.
- Set the angular step width $\Delta\beta = 0.0^\circ$.
- Press the COUPLED key to activate 2 θ coupling of target and sensor and set the target angle manually to 4.1° .

At $U = 35$ kV, the limit wavelength of the bremsstrahlung radiation is $\lambda_{\min} = 35.4$ pm (see e.g. experiment P6.3.3.3). This value corresponds to a diffraction angle of 3.60° in the first order of diffraction. The selected target angle of 4.1° corresponds to the wavelength $\lambda = 40.3$ pm. This is above the limit wavelength λ_{\min} and below the K-edges λ_K compiled in table 1.

- Set the measuring time per angular step to $\Delta t = 20$ s.
- Start the measurement with the SCAN key and display the mean counting rate R after the measuring time elapses by pressing REPLAY. Write down your results.
- Increase the measuring time per angular step to $\Delta t = 100$ s.
- Mount the Al foil from the set of absorbers (554 832) in the sensor seat (e) and start another measurement by pressing SCAN; display the mean counting rate after the measuring time elapses by pressing REPLAY, calculate the transmittance T by dividing this measured value by the value measured without an attenuator and write down your result.
- Replace the Al foil with the Fe, Cu, Zr and Ag foils one after another and conduct further measurements.

Measuring example

Tab. 2: Measured counting rates R and transmittance values T of the foils ($U = 35$ kV, $I = 0.6$ mA, $\beta = 4.1^\circ$)

Attenuator	$\frac{R}{s^{-1}}$	T
none	607.3	
Al	509.3	0.839
Fe	33.86	0.0558
Cu	327.0	0.538
Zr	280.6	0.462
Ag	107.0	0.176

Tab. 4: Absorption cross sections τ_a of the investigated elements

Element	Z	$\frac{\tau_a}{10^{-24} \text{ cm}^2}$
Al	13	49.44
Fe	26	662.7
Cu	29	1025
Zr	40	3574
Ag	47	5888

Tab. 3: Parameters of the foils

Element	Z	$\frac{\rho}{\text{g} \cdot \text{cm}^{-3}}$	$\frac{A}{\text{g} \cdot \text{mol}^{-1}}$	$\frac{x}{\text{cm}}$
Al	13	2.70	26.98	0.050
Fe	26	7.86	55.85	0.050
Cu	29	8.92	63.55	0.007
Zr	40	6.49	91.22	0.005
Ag	47	10.50	107.87	0.005

Results

Outside of the absorption edges, the absorption cross-section for a constant wavelength can be represented in the form

$$\ln \tau_a = A \cdot \ln Z + B$$

The slope of the line A has roughly the value 4, so that the Z^4 law applies:

Outside of the absorption edges, the dependence of the atomic cross-section on the atomic number Z can be approximately described for monochromatic x-ray radiation by the relation

$$\tau_a = C_2 Z^4$$

Evaluation

Table 2 shows the values determined for transmittance T . Table 3 summarizes important parameters for further evaluation. When we insert this data in equation (XI), we can calculate the absorption cross-section τ_a (see table 4 and Fig. 4). To confirm the Z^4 law, we must calculate the terms $\ln(\tau_a / 10^{-24} \text{ cm}^2)$ and $\ln Z$, represent the absorption cross-section in the form $\ln \tau_a = f(\ln Z)$ and fit a straight line (see Fig. 5).

Literature

[1] C. M. Lederer and V. S. Shirley, Table of Isotopes, 7th Edition, 1978, John Wiley & Sons, Inc., New York, USA.

Fig. 4 Absorption cross-section τ_a as a function of the atomic number at the wavelength $\lambda = 40$ pm

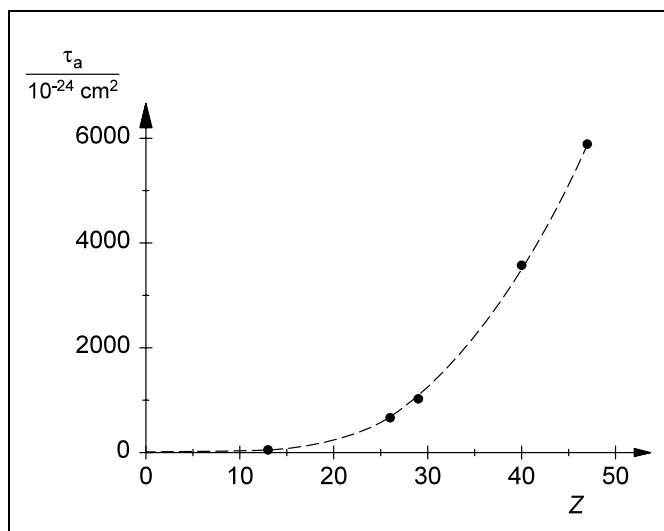

Fig. 5 Absorption cross-section τ_a as a function of Z in the representation $\ln \tau_a$. Slope of line: 3,75

