

Observing individual lycopod spores in a Paul trap

Objects of the experiment

- Observing lycopod spores in a Paul trap with varying suspension and offset voltages and orientations of the trap
- Observing a single lycopod spore in the center of the trap

Principles

Spectroscopic measurements of atomic energy levels are normally impaired by the motion of the atoms under study with respect to the radiation source. This motion shifts and broadens the spectral lines due to the Doppler effect, which becomes strongly apparent in high-resolution spectroscopy. The influence of the Doppler effect is reduced when individual atoms are enclosed in a small volume for spectroscopic measurements. For charged particles (ions), this can be achieved using the ion trap developed by *W. Paul* in the 1950's. It consists of two rotationally symmetrical cover electrodes and one ring electrode. The application of an AC voltage generates a time-dependent, parabolic potential with the form

$$U(r, z, t) = U_0 \cdot \cos \omega t \cdot \frac{r^2 - 2z^2}{2r_0^2}$$

z : coordinate on the axis of symmetry,

r : coordinate perpendicular to axis of symmetry,

r_0 : inside radius of ring electrode

An ion with the charge q and the mass m remains trapped in this potential when the conditions

$$0.4 \cdot \alpha < \frac{q}{m} < 1.2 \cdot \alpha \quad \text{where} \quad \alpha = \frac{r_0^2 \cdot \omega^2}{U_0}$$

are fulfilled.

The experiment demonstrates how a Paul trap works using a model which can be operated with no special requirements at standard air pressure and with 50 Hz AC. When a suitable voltage amplitude U_0 is set, it is possible to trap lycopod spores for several hours and observe them under laser light. Tilting of the entire ion trap causes the trapped particles to move radially within the ring electrode. When a voltage is applied between the cover electrodes, it is possible to shift the potential along the z -axis.

Apparatus

1 Paul trap	558 80
1 He-Ne-Laser, linearly polarized	471 830
1 Lens $f = 5$ mm.....	460 01
1 Auxiliary bench, 0.5 m	460 34
or	
1 Precision optical bench, 1 m.....	460 32
3 Optics rider	460 373
1 Power supply 450 V DC	522 27
1 Variable extra low voltage transformer S.....	521 35
1 U-core with yoke.....	562 11
1 Clamping device	562 12
1 Extra low voltage coil, 50 turns.....	562 18
1 Coil with 10,000 turns.....	562 16
1 Measuring resistor 10 M Ω	536 211
1 Multimeter LD-analog 20	531 120
1 Safety connection lead, 100 cm, black	500 644
2 Safety connection lead, 50 cm, black	500 624
1 Safety connection lead, 100 cm, red	500 641
1 Safety connection lead, 100 cm, blue.....	500 642
1 Set of 6 safety adapter sockets	500 98
2 Pair of cables, 50 cm, red and blue	501 45
1 Connection lead, 100 cm, yellow/green.....	500 440
1 Distribution box.....	502 04

Safety notes

Contact-hazardous high voltages can occur when operating the Paul trap.

- When working with contact-hazardous voltages sources, always be sure to use a series resistor.
- Connect the Paul trap only via safety connecting leads.
- Make sure all supply units are switched off before connecting the apparatus.

The He-Ne laser fulfills the European technical standard "Safety of laser equipment" – EN 60825-1 for class 2 lasers. When the precautions described in the Instruction Sheet are observed, experimenting with the He-Ne laser is not dangerous.

- Never look directly into the direct or reflected laser beam.
- Do not exceed the glare limit (i.e. no observer should feel dazzled).

Set up

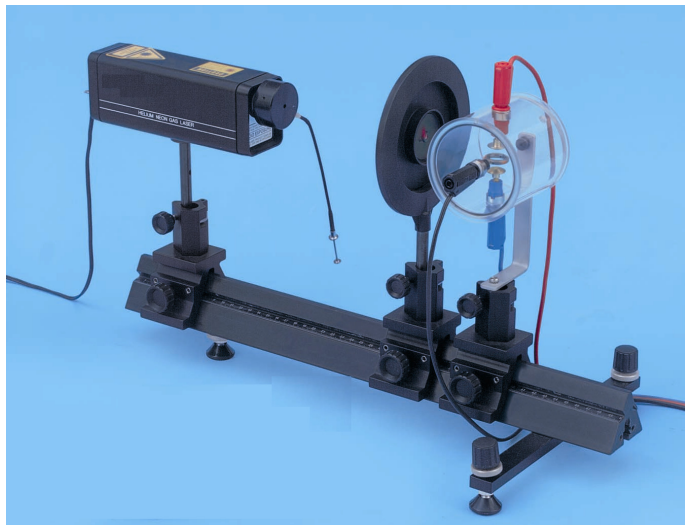

Fig. 1: Optical setup

Optical setup:

Mount the Paul trap and the He-Ne-laser in optic riders on the optical bench with a distance of 30 to 40 cm.

Adjust the laser and the Paul trap, so that the laser beam transmits the holes of the ring electrode.

Adjust lens $f = 5$ mm, so that the room between the outer electrodes is illuminated by the beam of the laser.

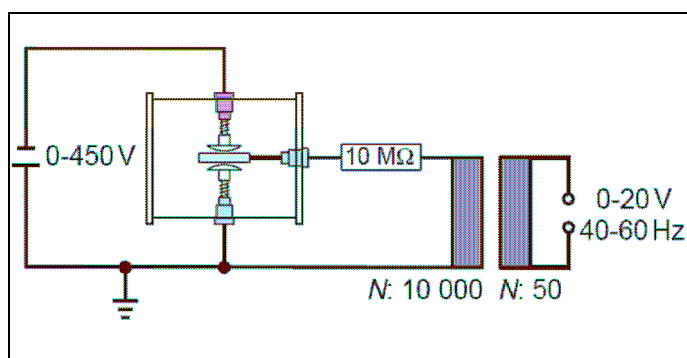

Fig. 2: Electrical setup

Electrical set up:

Set up the transformer with primary coil 50 turns and secondary coil 10,000 turns.

Connect the Paul trap as shown in fig. 2. Use the resistor $10\text{ M}\Omega$ and the electrical earth of the distribution box.

For measuring the primary voltage connect the multimeter to the output of the variable transformer.

Carrying out the experiment

- Set the suspension voltage U_0 to approximately 1000 V by setting the primary voltage of the variable transformer to 5 V.
- Using the wooden stick, take some lycopod spores from the bottle and place them in the center of the Paul trap through the filling opening.
- Find stability limits of the Paul trap by varying the suspension voltage U_0 .
- Displace the trapped lycopod spores axially in the Paul trap by varying the offset voltage U_1 .
- Displace the trapped lycopod spores radially from the center of the trap by turning the cylindrical housing.
- By increasing and decreasing the suspension voltage U_0 and the offset voltage U_1 it is possible to get a single lycopod spore inside the trap. Displace the single lycopod spore by varying the offset voltage U_1 .

Observing example

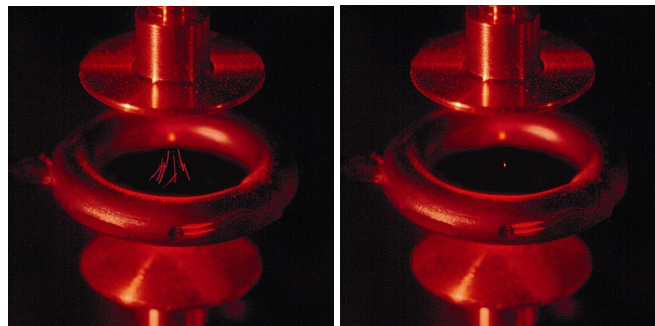

Fig. 3 (left): Lycopod spores inside the Paul trap

Fig. 4 (right): One single lycopod spore in the center of the Paul trap

Evaluation

With the model of the Paul trap it is possible to capture small electrical charged particles in a little region (of the quadrupol field).

Oscillating particles can be seen as small stripes, which show the orientation of the electric field. The location depends on the amplitude of the suspension voltage U_0 , the offset voltage U_1 and the orientation of the trap.

Variation of the offset voltage U_1 leads to a vertical shift. The direction depends on the polarity of the offset voltage U_1 and the charge of the particles.

One single particle can be held without visible oscillation in the center of the trap.