

Determining the gravitational constant with the gravitation torsion balance after Cavendish

Recording the excursion and evaluating the measurement with the IR position detector and PC

Objects of the experiment

- To record the damped oscillations around the final equilibrium positions of the torsion pendulum as a function of time.
- To calculate the gravitational constant G using the end-deflection method.
- To calculate the gravitational constant G using the acceleration method.

Principles

The heart of the gravitation torsion balance according to Cavendish is a light transverse beam, horizontally suspended by a thin torsion string, which supports a small lead ball with the mass m_2 at each end at a distance d from the suspension point. These two balls are attracted by two large lead spheres with the mass m_1 . Although the force of attraction is less than 10^{-9} N, it is still possible to demonstrate this attraction using the extremely sensitive gravitation torsion balance. The motion of the small lead balls is observed and measured using the IR position detector (see Fig. 1).

The IR position detector has four infrared diodes which illuminate a concave mirror which is mounted in a fixed position on the transverse beam of the torsion pendulum. The reflected light is projected onto a row of phototransistors to register the oscillations of the mass m_2 . On the basis of the motion over time, the mass m_1 and the geometry of the setup, it is possible to determine the gravitational constant using the end-deflection method or – in an abbreviated measuring procedure – by means of the acceleration method.

Fig. 1: Gravitation torsion balance according to Cavendish (left), and schematic diagram of the experimental setup (right).

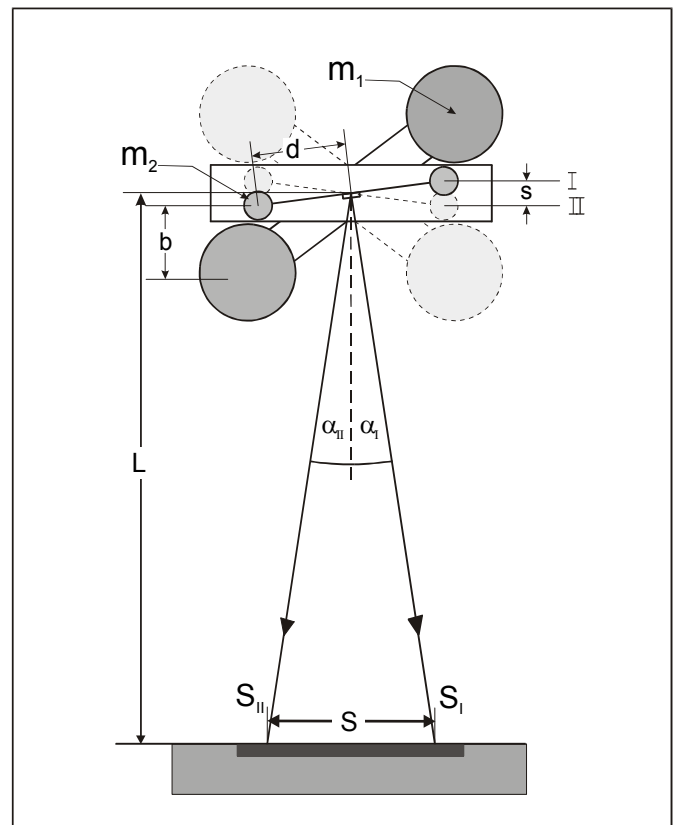
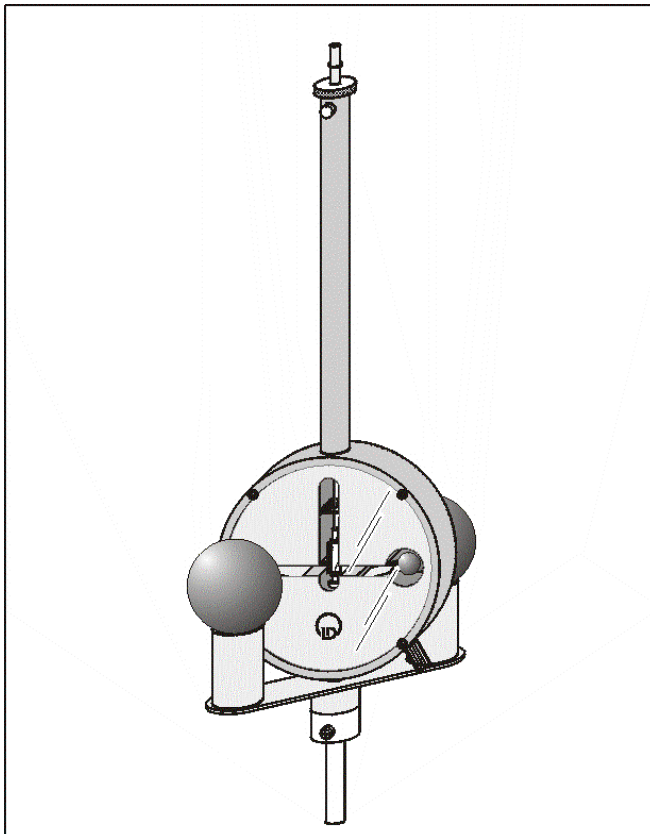

Apparatus

1 Gravitation torsion balance	332 101
1 IR position detector (IRPD)	332 11
1 Optical bench, standard cross section 1 m	460 32
1 Optics rider 60/50	460 373
1 Optics rider 90/50	460 374
1 Stand rod, 25 cm	300 41

additionally required: 1 PC with Windows 98 or higher

a) End-deflection method

The end-deflection method is based on the observation that the gravitational force between two lead spheres with the masses m_1 and m_2 at a distance b is given by (Fig. 1):

$$F = G \cdot \frac{m_1 m_2}{b^2} \quad (I)$$

Thus, the moment of momentum M_I acting on the torsion pendulum is

$$M_I = 2 \cdot F \cdot d = 2 \cdot G \cdot \frac{m_1 m_2}{b^2} \cdot d \quad (II)$$

when the two large lead spheres of mass m_1 are in position I (see Fig. 1). The moment of momentum is compensated by the righting moment of the torsion cord. The torsion pendulum thus assumes the equilibrium position s_I .

By swiveling the large lead spheres in position II the forces are symmetrically inverted. The moment of momentum acting on the bodies is now $M_{II} = -M_I$. The pendulum executes damped oscillations around the equilibrium position s_{II} . For the difference of the two moments of momentum we have with the corresponding angles α_I and α_{II} :

$$D \cdot (\alpha_I - \alpha_{II}) = M_I - M_{II} = 2 \cdot M_I \quad (III)$$

The angular directional quantity D can be determined from the oscillation period T and the moment of inertia J of the torsion pendulum:

$$D = \frac{4 \pi^2}{T^2} \cdot J \quad (IV)$$

The moment of inertia J is equivalent to the moment of inertia of the two small balls:

$$J = 2 m_2 d^2 \quad (V)$$

Thus, equation (IV) is transformed to

$$D = \frac{8 \pi^2}{T^2} \cdot m_2 \cdot d^2 \quad (VI)$$

From equations (I), (III) and (IV) we obtain

$$G = \frac{2 \pi^2}{T^2} \cdot \frac{b^2 \cdot d}{m_1} (\alpha_I - \alpha_{II}) \quad (VII)$$

From geometry follows the relationship (here for position)

$$\tan 2\alpha = \frac{S_I}{L}$$

from which follows for small angles:

$$\alpha = \frac{S_I}{2L} \quad (VIII)$$

By using this equation (VIII) equation (VII) can be written as follows (for further details see instruction sheet 332 11 or leaflet P1.1.3.1):

$$G = \frac{2 \pi^2}{T^2} \cdot \frac{b^2 \cdot d}{m_1} \frac{(S_I - S_{II})}{L} \quad (IX)$$

b) Acceleration method

Directly after the large lead spheres are slewed from position I to position II, the small balls are subjected to an acceleration a_0 which follows from the equation of motion:

$$m_2 \cdot a_0 = 2 \cdot G \cdot \frac{m_1 m_2}{b^2} \quad (X)$$

Thus the gravitational constant is given by:

$$G = \frac{a_0 b^2}{2 m_1} \quad (XI)$$

The acceleration a_0 applied to the masses m_2 can be determined from the acceleration a'_0 of the light reflection from the geometry relationship as follows:

$$a_0 = a'_0 \frac{d}{2L} \quad (XII)$$

As the path is given by

$$s(t) = \frac{1}{2} a_0 t^2 \quad (XIII)$$

the acceleration a'_0 can be obtained by fitting a parabola of the general form

$$s(t) = A \cdot t^2 + B \cdot t + C \quad (XIV)$$

to the first phase of the motion. The comparison of equation (XIII) with equation (XIV) gives:

$$a'_0 = 2 \cdot A$$

With equation (XII) the gravitational constant is given by:

$$G = a'_0 \frac{db^2}{4 m_1 L} \quad (XV)$$

Safety notes

Mind the instruction sheets for the *gravitation torsion balance* and the *infrared position detector*.

- Protect the sensitive band of the gravitation torsion balance from uncontrolled mechanical loading.
- Always look the oscillation system of the gravitation torsion balance when the device is not used.
In particularly, make sure the oscillating system is locked during transport and assembly.
- The sensitive electronics of the IR position detector can be impaired or damaged by electrostatic discharge.
- Chose an experiment area where no electrostatic charges can be build up on either the operator or the devices.

Setup

Important: satisfactory measuring results are only possible when the torsion balance is adjusted properly. In addition, the torsion oscillations caused by the attraction between the masses must not be disturbed by undesired pendulum motions. The torsion pendulum is extremely sensitive to shocks transmitted to the housing of the torsion balance. Changes in temperature cause convection currents in the housing of the torsion balance, which in turn results in unwanted movements of the torsion pendulum.

Choose a stable experiment setup on a solid wall.

Select an experiment site which is not exposed to direct sunlight or drafts. When slewing the sphere support avoid shocks to the housing. e.g. by knocking at the setup with the lead spheres.

Fig. 2 shows the experimental setup.

Assembling the gravitation torsion balance before using it the first time:

- Assemble a benchtop for the experimental setup on the wall like shown in Fig. 2 (see also instruction sheets 332 101 and 322 11).
- Setup the optical bench with the gravitation torsion balance.
- Position the gravitation torsion balance (without the large lead spheres) so that there is sufficient space to turn the supporting arm of the lead spheres.
- Loosen the arresting mechanism of the torsion pendulum and correct the alignment so that the pin at the end of the pendulum hangs in the middle of the rod hole and make sure that the torsion pendulum can swing freely.
- Allow the torsion pendulum to hang for one to two days and readjust the zero point if necessary (see instruction sheet 332 101).

Setting the distance between the gravitation torsion balance and the IR position detector for the first time:

- Clamp the IR position detector on the rear panel to stand rod which is inserted in the rider on the optical bench.
- Setup IR position detector on the optical bench in such a manner that the distance between the front window of the gravitation balance and the IR position detector is 70 cm.
- Connect power supply 12 V AC to the IR position detector and adjust the window with infrared LEDs roughly to the same level as the mirror of the gravitation torsion balance.
- The two red adjustment LEDs now light up so brightly that their mirror image can be seen in the plane of the device, either on the device itself or on a sheet of white paper which is held beside it:
 - If the image is to the *left or right of the window*, oscillate the gravitation torsion balance slowly so that the mirror image of the bright LEDs passes across the front panel.
 - If the image is *above or below the window*, project it onto the center by raising or lowering the IRPD.
- Ensure that the row of photo transistors is situated in the plane which is covered by the mirror so that all of the photo transistors are used for measuring.
- Adjust the height by using the green and red LEDs. Assuming that the photo transistor row is in the plane illuminated by the mirror these LEDs are switched on and off depending on the luminous intensity of the phototransistors:
 - Red LED flickers: illumination/adjustment sufficient
 - Green LED flickers: illumination/adjustment good

Fig. 2: Experimental setup: Benchtop assembly of the gravitation torsion balance with electronic recording of the oscillation curve using the IR position detector.

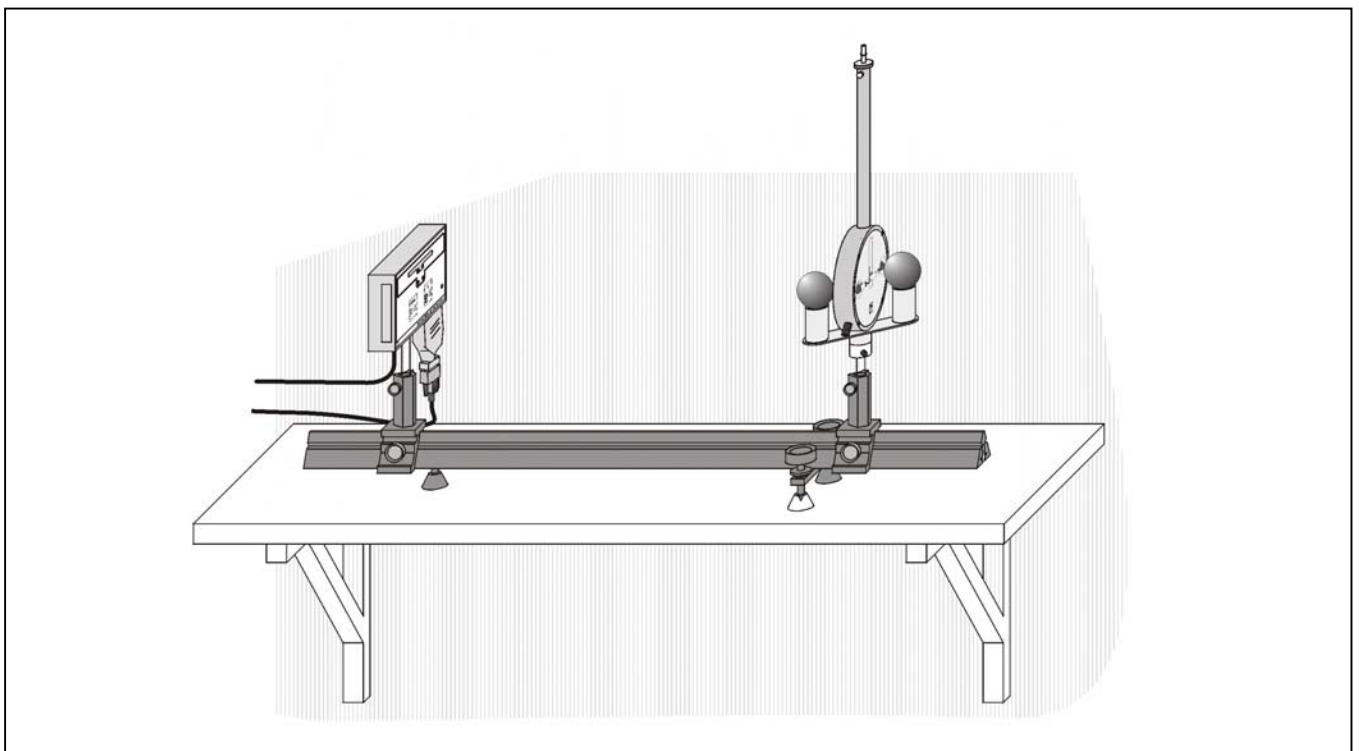

Recording the oscillations

- Connect the IR detector to the computer via the RS232 port.
- If not yet installed install the software and open the software (preconfigured CASSY Lab user interface)
- Open the window "Settings" using the tool box button  or function key F5 from the top button bar:



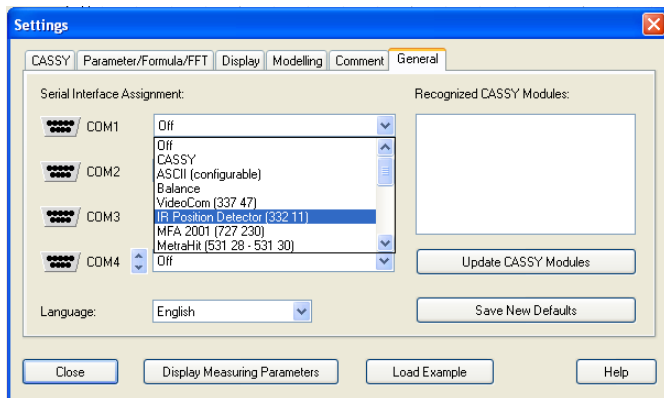

- Select the tab "General" in the window "Settings" and set the appropriate COM port by selecting the IR position detector:

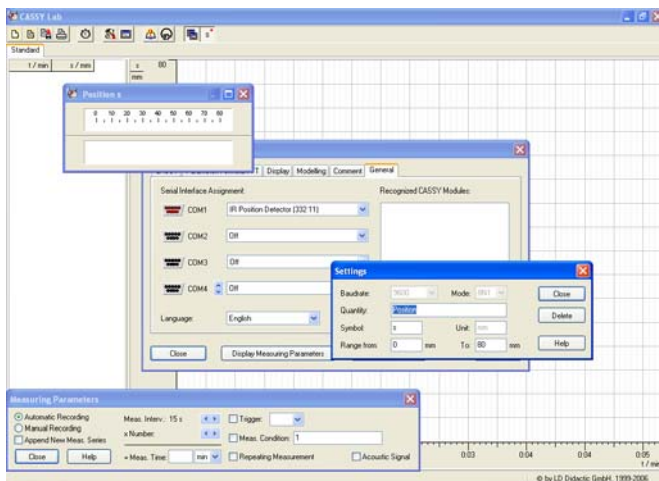

After selecting the IR position detector for the appropriate Com port the software opens a table, display and various windows: indicator for the measuring quantity, i.e. the window "Position s", the window "Settings" and the window "Measuring Parameters":



- Accept the preset values by closing all windows inside the main window.
- Press the button  or function key F9 to start recording the oscillations of the gravitation torsion balance.

Note: The button  works as a toggle switch. The data acquisition can be stopped by pressing  or F9.

These adjustments of the experimental setup have to be performed only once because the rest position is retained after the gravitation torsion balance has been locked.

Carrying out the experiment

First Preparation



- Allow the setup to stand for at least two hours undisturbed by shocks, so that the pendulum can come to rest in one of the equilibrium position.

Note: Typical equilibrium positions for a good adjustment are approximately 20 mm and 50 mm, respectively. If this is not fulfilled the gravitation torsion balance has to be rotated by a small angle. It might be necessary to repeat this step several times.

If the arresting screw has been loosened after a long period of disuse, the torsion pendulum may require more time to settle into an stable equilibrium position.



- Check the stability of the zero point by recording the baseline. Started data acquisition by the button .
- Measure the zero-point fluctuations for at least 10 minutes.

a) End-deflection method

- Wait until the system settles into a stable equilibrium position (see above first preparation).
- You may clear the baseline measurement with the button  or the function key F4.
- Start data acquisition by pressing the button  or F9.
- Move the supporting arm with the lead spheres rapidly (but carefully!) from position I to position II.
- Swivel the lead spheres from position II back to position I and repeat the measurement for the oscillations around the equilibrium position I.
- Stop the data acquisition by pressing the button  or F9.

Note: You may save your measurements by pressing the button  or using the function key F2.

b) Acceleration method

- Wait until the system settles into a stable equilibrium position (see above first preparation).
- You may clear the baseline measurement with the button  or the function key F4.
- Start the data acquisition by pressing the button  or F9.
- Move the supporting arm with the lead spheres rapidly (but carefully!) from position I to position II and record the first phase of the motion.
- Stop the data acquisition by pressing the button  or F9.

Note: As this experiment uses the IR position detector for recording the oscillations of the gravitation torsion balance the acceleration method is automatically included when performing the end-deflection method. The "measurement interval" is set to an appropriate value, e.g. 15 s.

Measuring example

Fig. 3 shows an illustration of damped oscillations of the gravitation torsion balance and the two corresponding final positions. While swiveling the lead spheres from position II back to position I the data acquisition was not switched off.

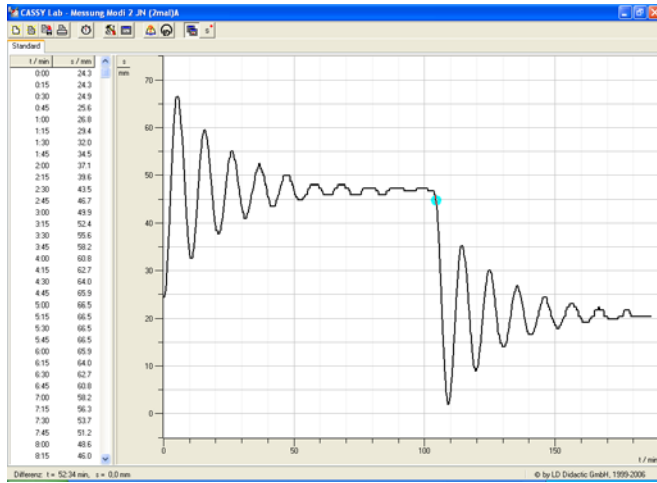

Fig. 3: Oscillations at the equilibrium positions I and II of the gravitation torsion balance according to Cavendish.

Evaluation

The software allows an easy evaluation of the measured data. To access the data evaluation tools click with right mouse button into the display (plot) to open the pop up menu.

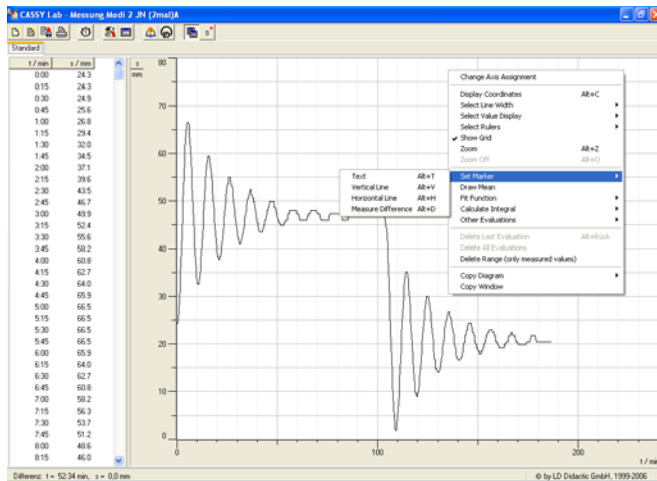

Fig. 4: Accessing the data evaluation tools by clicking with the right mouse button into the display.

a) End-deflection method

Note: The zoom tool (Alt-Z) might be useful to enlarge the plot of the recorded data. Alternatively, the scale of the display can be changed by clicking with the right mouse button into the x- or y-axis area.

Determining the equilibrium positions I and II

The two stable final equilibrium positions I and II of the two suspended small lead balls can be determined as follows:

- Calculate the mean average of e.g. position I by selecting the tool “Draw the Mean”
- Select the end part of the recorded oscillation by dragging over data the mouse pointer (selected data become blue).
- Plot the result of the calculation into the display by selecting the tool “Text” form the “Set Marker” popup menu (or Alt-T). Alternatively, the result can be dragged from the status line (left window bottom) into the display (Fig. 5).
- Repeat the evaluation for position II.

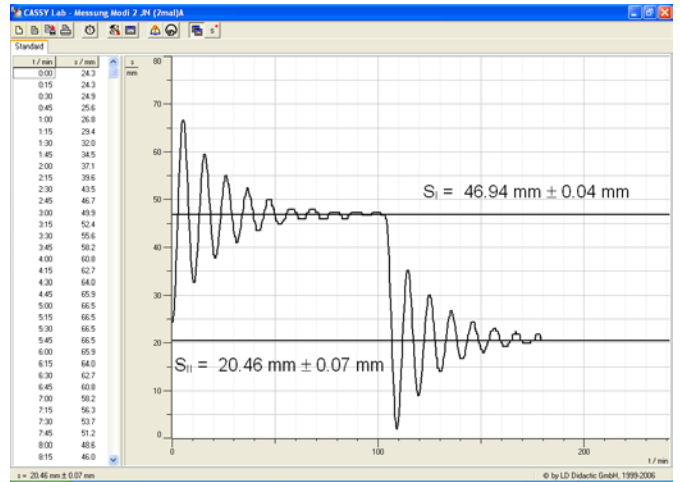

Fig. 5: Determining the equilibrium positions I and II by calculating the mean values S_I and S_{II} at the end of the oscillations.

Determining the oscillation period

- Select the “Measure Difference tool” by Alt-D (or by clicking the right mouse button into the display and choosing the submenu “Select Marker”)
- Measure the period e.g. over 5 oscillations by clicking at the plot when the oscillation first passes the mean value S_I and then click at the plot when 5 oscillations have been elapsed.
- The result of the evaluation can be displayed using e.g. Alt-T. Alternatively, the result can be dragged from the status line into the display (Fig. 6).
- Repeat the evaluation for the oscillation around the stable position II.

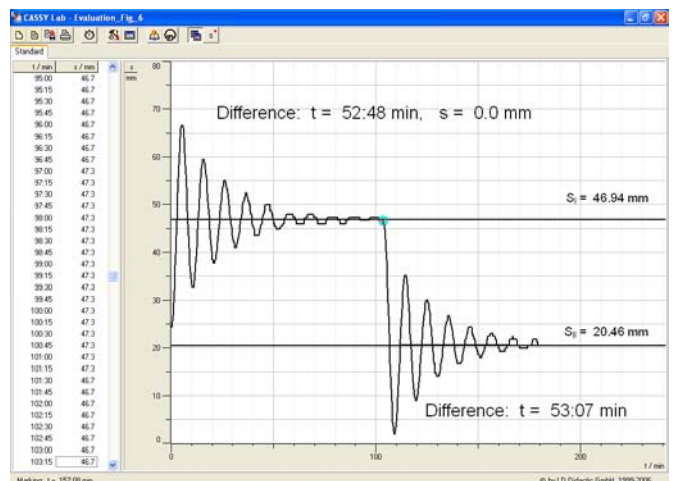

Fig. 6: Determining the oscillation period over 5 periods for the oscillations at positions I and II. (Note: The text of mean values for S_I and S_{II} of Fig. 5 was changed for sake of clarity.)

b) Acceleration method

- Zoom the data around the first phase of the motion, e.g. at position II, and fit a parabola to the recorded data.
- The result of the evaluation can be displayed in the plot by Alt-T.

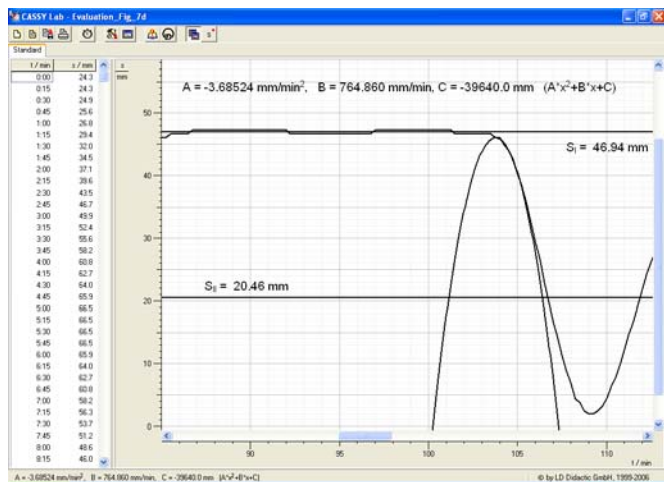

Fig. 7: Determining the acceleration for the first phase of the oscillation after swiveling the lead spheres from position II back to position I (for smaller zoom range see Fig. 8).

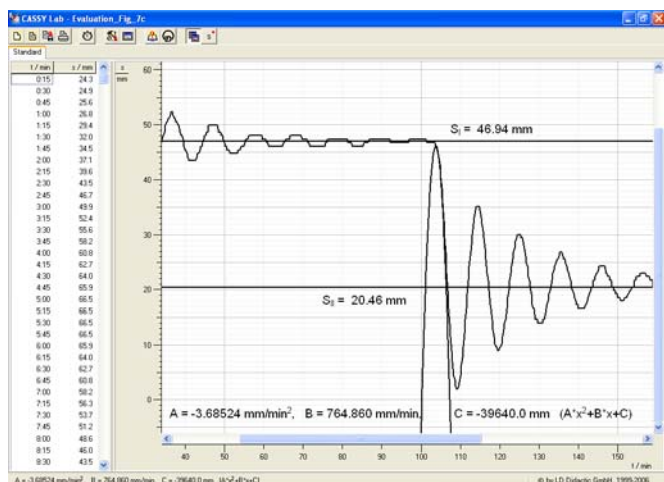

Fig. 7: Determining the acceleration for the first phase of the oscillation after swiveling the lead spheres from position II back to position I (for larger zoom range see Fig. 7).

Results

a) End-deflection method

The calculation of the sample measurement of Fig. 5 and Fig. 6 shows:

Period of oscillation $T = 634 \text{ s}$

The difference between the two final positions:

$S = S_{II} - S_I = 26.5 \text{ mm}$

Substituting these values into equation (IX) we obtain:

$$G = \frac{2\pi^2}{634^2 \text{ s}^2} \cdot \frac{0.047^2 \text{ m}^2 \cdot 0.05 \text{ m}}{1.5 \text{ kg}} \cdot \frac{0.026 \text{ m}}{0.7 \text{ m}}$$

$$G = 6.71 \cdot 10^{-11} \frac{\text{m}^3}{\text{kg s}^2}$$

Literature value: $G = 6.67 \cdot 10^{-11} \frac{\text{m}^3}{\text{kg s}^2}$

b) Acceleration method

From matching a parabola to first phase of the oscillation after swiveling the lead spheres from position II back to position I (see Fig. 7) we obtain:

$$A = 1.03 \cdot 10^{-6} \frac{\text{m}}{\text{s}^2}$$

$$a'_0 = 2.05 \cdot 10^{-6} \frac{\text{m}}{\text{s}^2}$$

$$G = 1.33 \cdot 10^{-6} \frac{\text{m}}{\text{s}^2} \cdot \frac{0.05 \text{ m} \cdot 0.047^2 \text{ m}^2}{4 \cdot 1.5 \text{ kg} \cdot 0.7 \text{ m}}$$

$$G = 5.4 \cdot 10^{-11} \frac{\text{m}^3}{\text{kg s}^2}$$

Supplementary information

For a detailed treatment of the geometrical relations and the resulting their errors refer to the alternative light pointer method, i.e. leaflet P1.1.3.1.