

## Standing transversal waves on a string

### Objects of the experiment

- Investigating transversal waves on an elastic string fastened at both ends.
- Generating standing waves as a function of the excitation frequency  $f$ .
- Determining the wave velocity  $v$ .

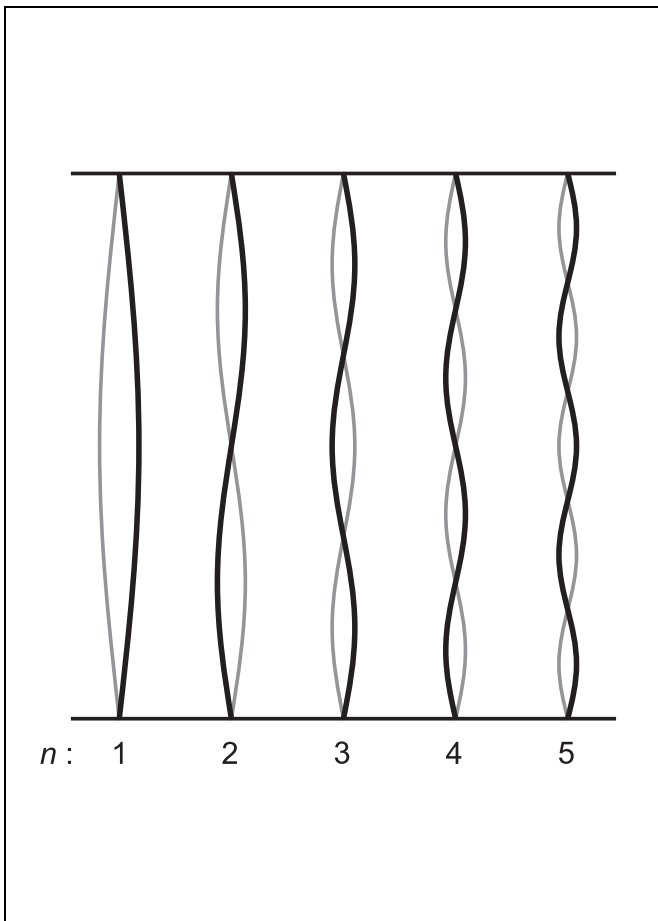

Standing transversal waves on a string

### Principles

A wave is formed when two systems capable of coupled oscillation sequentially execute oscillations of the same type. One example of this is the propagation of a transversal wave along an elastic string.

The propagation velocity of an oscillation state is related to the oscillation frequency  $f$  and the wavelength  $\lambda$  through the formula

$$v = \lambda \cdot f \quad (I)$$

This is termed the wave or phase velocity and depends on the tension of the string, among other factors.

When the string is fixed at both ends, reflections occur at the ends. Standing waves form at certain frequencies as stationary oscillation patterns. The distance between two oscillation nodes or two antinodes of a standing wave corresponds to one half the wavelength. Only oscillation nodes can form at the fixed ends. For a standing wave with  $n$  oscillation antinodes on a string with the length  $s$ , we can say

$$s = n \cdot \frac{\lambda_n}{2} \text{ with } n = 1, 2, 3, \dots \quad (II)$$

As the phase velocity  $v$  does not change, (I) implies the excitation frequencies:

$$f_n = \frac{v}{2s} \cdot n \quad (III)$$

In this experiment, a vertically mounted rubber string is caused to oscillate by means of an electric motor with an oscillation lever at one end of the string. The excitation frequency is continuously adjustable using a function generator.

**Apparatus**

1 Rubber string . . . . .	200 66 629
1 STE motor with flywheel . . . . .	562 791
1 Function generator S12, 0.1 Hz – 20 kHz . . . . .	522 62
1 Transformer, 6 V AC, 12 V AC/30 VA . . . . .	562 73
1 Pair of cables, 1 m, red and blue . . . . .	501 46
2 Stand bases . . . . .	301 21
1 Clamping block MF . . . . .	301 25
1 Stand rod, 25 cm . . . . .	301 26
2 Stand rod, 50 cm . . . . .	301 27
1 Pair of pointers . . . . .	301 29
1 Support clip, for plugging in . . . . .	314 4
1 Universal bosshead, 28 mm dia., 50 mm . . . . .	666 615
1 Tape measure, 1.5m/1 mm . . . . .	311 78

Set up the experiment as shown in Fig. 1.

- Connect the stand bases using the short stand rod.
- Connect the long stand rods using the universal bosshead and mount them in the stand base.
- Attach the STE motor (a) in the stand base using the cables and connect it to the function generator (see Fig. 1).
- Clamp the pointer to the stand rods and attach the clamping block (b) with plugged-in holder to the top stand rod.
- Tie a rubber string about 75 cm long (unstretched) to the oscillation lever and the support clip, then stretch it by about 5 to 10 % by moving the clamping block.
- Connect the function generator to the 12 V output of the transformer.
- On the function generator, set the output voltage  $U = 3 V_P$ , frequency range "x 10 Hz" and signal form "~"

**Setup**

Fig. 1 Experiment setup for generating standing transversal waves on a string

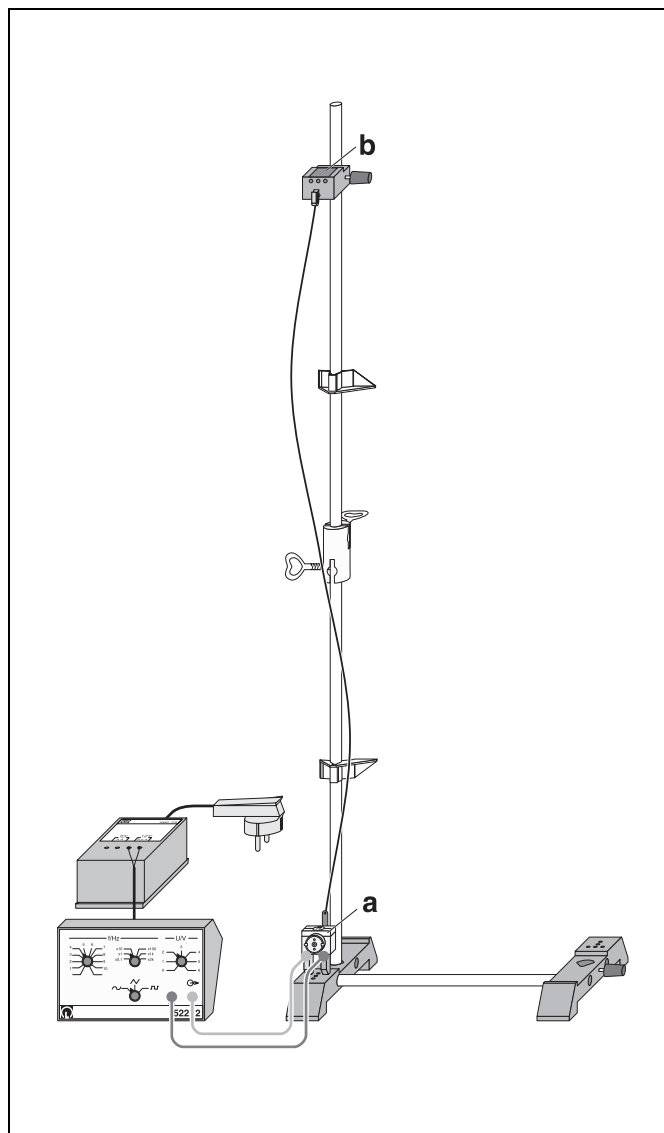

**Carrying out the experiment**

*Note: Depending on the excitation frequency  $f$ , oscillation states are generated in which the string end attached to the oscillation lever oscillates at a greater amplitude. However, you need to find the frequencies which excite stationary oscillation states at which the oscillation lever moves the least and can be regarded as a fixed end.*

- Set the frequency of the function generator so that a standing wave with two oscillation antinodes is formed, and optimize the oscillation by moving the clamping block.
- Measure the length  $s$  of the extended rubber string.
- Turn the frequency control knob to the minimum position (full left stop).
- Slowly increase the frequency  $f$  and carefully seek those frequencies at which standing waves with  $n = 1, 2, 3, 4$  and  $5$  antinodes are formed.
- Read off the frequency from the scale of the control knob and write this value down.

*Note:*

*Depending on the length and the tension of the rubber string, it can be difficult to generate exactly one antinode.*

*Vary the string tension as necessary.*

**Measuring example**

$s = 79 \text{ cm}$

$n$	$\frac{f}{\text{Hz}}$
1	15
2	34
3	54
4	71
5	91

**Evaluation and results**

Fig. 2 shows the excitation frequency  $f$  as a function of the number of oscillation antinodes  $n$ . The fitted straight line of the relation

$$f_n = a \cdot n$$

has the slope

$$a = 17.9 \text{ Hz}$$

From (III), we can derive for this slope

$$a = \frac{v}{2s}$$

As the length  $s$  of the string is known, we can calculate the phase velocity:

$$v = 2s \cdot a = 28.3 \frac{\text{m}}{\text{s}}$$

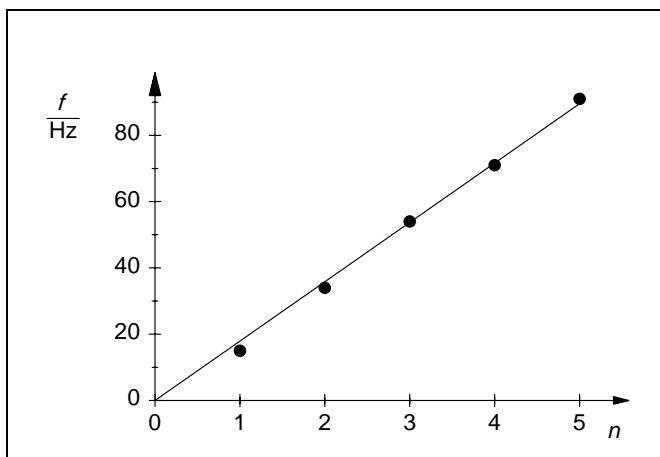

Fig. 2 Excitation frequency  $f$  for generating standing waves as a function of the number of oscillation antinodes  $n$ .

**Additional information**

The excitation frequency set on the frequency generator is affected by feedback from the STE motor. Consequently, a stroboscope (e.g. 451 281) is recommended to precisely determine the oscillation frequency of the string.

