

Mechanics

Rotational motions of a rigid body
Conservation of angular momentum

Conservation of angular
momentum in rotational
collision

Description from CASSY Lab 2

For loading examples and settings,
please use the CASSY Lab 2 help.

Conservation of angular momentum and energy (torsion collision)

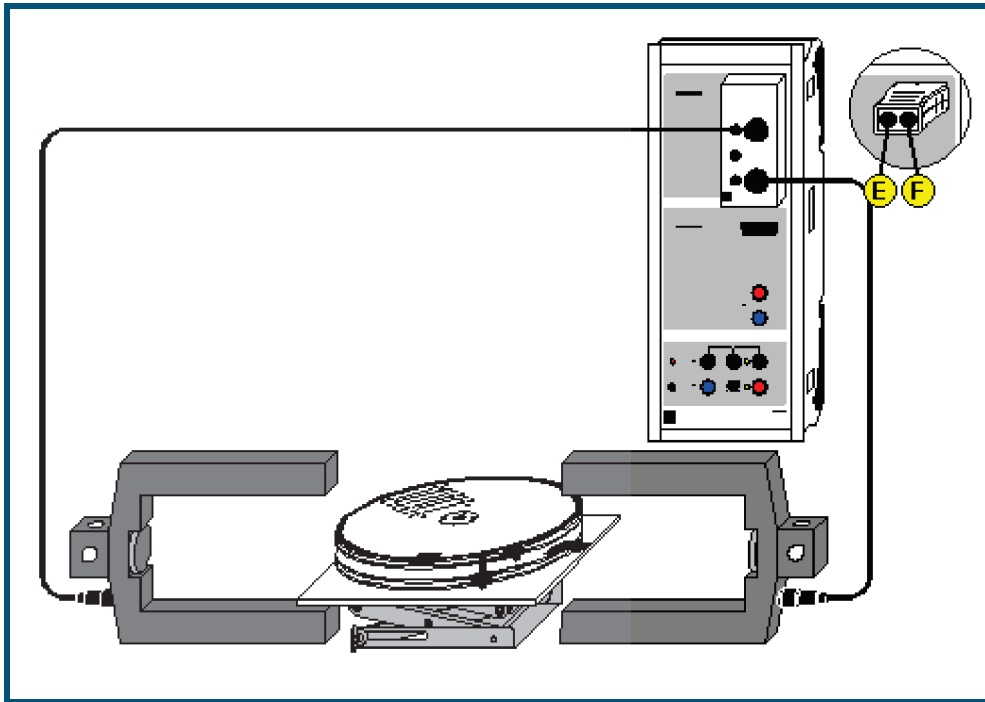

 can also be carried out with [Pocket-CASSY](#)

Experiment description

With the rotation model, the angular velocities ω of two bodies before and after their collisions can be measured from the obscuration times of two light barriers. By this means, it is possible to verify the law of conservation of angular momentum for elastic and inelastic torsion collision, as well as that of conservation of energy for elastic torsion collision.

Equipment list

1	Sensor-CASSY	524 010 or 524 013
1	CASSY Lab 2	524 220
1	Timer box or Timer S	524 034 or 524 074
1	Rotation model	347 23
2	Forked light barriers	337 46
2	Multi-core cables, 6-pole, 1.5 m	501 16
1	Laboratory stand II	300 76
1	PC with Windows XP/Vista/7	

Experiment setup (see drawing)

First position the rotation model and the two light barriers (connected to inputs E and F of the timer box) so that the flags of the rotating bodies are **between** the light barriers when torsion collision occurs. The flags of the two bodies must interrupt the light barriers when they pass through.

Carrying out the experiment

■ Load settings

- Enter the moments of inertia J_1 and J_2 in the table (activate keyboard input in the cells beneath J_1 and J_2 with the mouse).
- Enter the arrangement of the flags before collision in relation to light barriers E and F ([Settings \$\omega_1, \omega_2, \omega_1'\$ or \$\omega_2'\$](#)). There are four different arrangements:
Both flags outside of light barriers.
Left flag between the light barriers, right flag outside.
Left flag outside the light barriers, right flag between them.
Both flags inside (explosion).
- Enter the flag width and radius (also in [Settings \$\omega_1, \omega_2, \omega_1'\$ or \$\omega_2'\$](#)).

- Initiate the collision (if angular velocities are displayed before the collision, you can clear these with $\rightarrow 0 \leftarrow$) and watch to make sure that the light barriers do not register any extra pulses (e.g. due to reflection of a rotating body).
- Terminate the measurement with **End of Collision** (the measurement is terminated automatically after four measured angular velocities).
- Transfer the measured values to the table for evaluation with  or initialize the next measurement with $\rightarrow 0 \leftarrow$.

Evaluation

Tables have been pre-defined for angular momentum before and after collision, overall angular momentum, energy, total energy and energy loss; you can transfer measured values to these with . Click on the table tabs to display these. If you want these quantities to be visible immediately after collision, open the corresponding display instruments.

You can also define additional [formulas](#) to compare your results with theory. For elastic torsion collision, we say that

$$\omega_1' = (2 \cdot J_2 \cdot \omega_2 + (J_1 - J_2) \cdot \omega_1) / (J_1 + J_2)$$

$$\omega_2' = (2 \cdot J_1 \cdot \omega_1 + (J_2 - J_1) \cdot \omega_2) / (J_1 + J_2)$$

For inelastic torsion collision, the following applies:

$$\omega_1' = \omega_2' = (J_1 \cdot \omega_1 + J_2 \cdot \omega_2) / (J_1 + J_2).$$

In all formulas, the character combination ω plus w is used to represent (and generate) the Greek ω .

Table for converting specified units to SI units

Quantity	SI unit =	Factor	· specified unit
Moment of inertia J	kg·m ²	1000	g·m ²
Angular velocity ω	rad/s	1	rad/s
Angular momentum L	N·s·m = kg·m ² /s	1000	mJ·s
Energy E	J = kg·m ² /s ²	1000	mJ

