

Uniformly accelerated motion with reversal of direction

Recording and evaluating with VideoCom

Objects of the experiments

- Recording the path-time diagram of a uniformly accelerated motion with reversal of direction.
- Determining the velocity v and the acceleration a as functions of time.
- Determining the kinetic energy and the total energy.

Principles

Uniform acceleration and reversal of direction:

On an inclined plane, a mass point is subject to a uniform acceleration a in the direction of the slope of the plane. If the initial velocity of the mass point is 0, the mass point covers the path

$$s_0 = \frac{1}{2} \cdot a \cdot t_0^2 \quad (I)$$

in the time t_0 and attains the velocity

$$v_0 = a \cdot t_0 \quad (II).$$

From (I) and (II)

$$t_0 = \sqrt{\frac{2 \cdot s_0}{a}} \quad (III)$$

and

$$v_0 = \sqrt{2 \cdot s_0 \cdot a} \quad (IV).$$

is obtained. The acceleration of the mass point does not change if the mass point moves uphill. In this case, the magnitude of its velocity decreases. Such a reversal of direction takes place, e.g., when the mass point is reflected elastically

at the position s_0 (see Fig. 1). As the mass point impinges on the reflecting wall at the velocity v_0 , its initial velocity after reflection is $-v_0$. It continues its motion at the velocity

$$v(t) = -v_0 + a \cdot (t - t_0) \quad (V)$$

and reaches the position

$$s(t) = s_0 - v_0 \cdot (t - t_0) + \frac{1}{2} a \cdot (t - t_0)^2 \quad (VI)$$

at the time t . At the time

$$t_1 = t_0 + \frac{v_0}{a} \quad (VII)$$

the mass point reaches the position $s(t_1 = 0)$ at the velocity $v(t_1 = 0)$. After that the velocity becomes positive, that is, the direction is reversed anew.

At the time

$$t_2 = t_0 + 2 \cdot \frac{v_0}{a} \quad (VIII)$$

the mass point again reaches the reflecting wall, i.e. the position s_0 , at the velocity v_0 . Altogether its path-time curve is a parabola with the vertex $P = (t_1, 0)$.

Because of Eq. (V) the kinetic energy of the mass point is

$$E_{\text{kin}} = \frac{1}{2} \cdot m \cdot v^2 = \frac{1}{2} \cdot m \cdot (a \cdot (t - t_0) - v_0)^2 \quad (IX).$$

Because of Eq. (VI) its potential energy, the product of the force acting in the direction of the slope and the path length from s_0 to s , is

$$E_{\text{pot}} = F \cdot (s_0 - s) = m \cdot a \cdot \left(v_0 \cdot (t - t_0) - \frac{a}{2} \cdot (t - t_0)^2 \right) \quad (X).$$

A simple calculation confirms that the sum of the two energies is constant.

Fig. 1 Acceleration a on an inclined plane

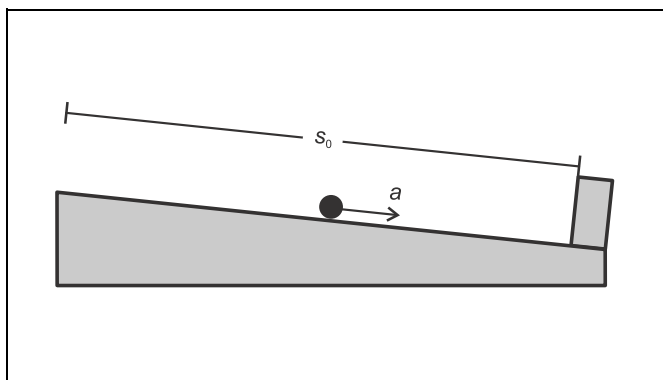

Apparatus

1 linear air track	337 501
1 air supply for air track	337 53
1 power controller	337 531
1 VideoCom	337 47
1 plug-in unit 230 V / 12 V AC / 20 W	562 791
1 camera tripod	300 59
1 metal scale	311 02

additionally required:

- 1 PC with Windows 95 / 98 / NT
- 1 massive block, $m > 0.7$ kg

Recording the motion with VideoCom:

In the experiment, the uniformly accelerated motion of a slider on an inclined linear air track is studied. At the lower end of the air track the slider is reflected by a massive block. The motions of the slider are recorded with the single-line CCD camera VideoCom, which illuminates a retroreflecting foil attached to the slider with LED flashes and images the reflected flashes on a CCD line with 2048 pixels with a camera lens (CCD: charge-coupled device). Up to 80 times per second the present position of the slider is transferred to a computer via a serial interface.

A computer program for VideoCom represents the entire motion of the slider as a path-time diagram and makes possible further evaluation of the measured values. In particular, computation of the velocity and of the acceleration can be activated with a mouse click.

Setup

The experimental setup is illustrated in Fig. 2.

Setting up the linear air track:

- Mount the track rail on the track stand, set it up, and align it horizontally with the adjusting screws (see instruction sheet of the linear air track) using a spirit level.
- Plug the adapter for air supply (**a**) into the air inlet.
- Connect the air supply to the power controller; connect the tubing to the adapter for air supply (see instruction sheet of linear air track).
- Attach the holding magnet with a clamping rider (**c**) near the air inlet, and put the brake (**g**) onto the other end of the track.
- Switch the air supply on, put the slider on the linear air track, and readjust the track with the adjusting screws until the slider remains at rest at several places of the track rail.
- Lift the air track on the side where the air is supplied so that the slider moves at an appropriate velocity along the track.

Setting up VideoCom:

- Screw VideoCom onto the camera tripod, set it up at a distance of approx. 2 m from the linear air track, and align it in height with the linear air track parallel to the track rail.
- Supply VideoCom with power via the plug-in unit, and connect it to a serial input of the PC (e.g. COM1).
- Connect the holding magnet to VideoCom via two connection leads (see instruction sheet of VideoCom).
- If necessary, install the VideoCom software on a PC with Windows 95/98/NT, call the program "VideoCom Motions" and, if necessary, choose the desired language and the serial interface (see instruction sheet of VideoCom).

Aligning VideoCom:

- Equip two sliders with interrupter flags (**d**) and stick retro-reflecting foil on both of them.
- Move the first slider to the holding magnet, and put the second slider on the linear air track while the air supply is switched off so that the distance between the two interrupter flags is exactly 1 m.
- Click "Intensity Test" in the program "VideoCom Motions".
- Slightly darken the room in order to minimise the background.
- Align VideoCom so that two peaks are visible on the LC display on the housing of the camera or on the screen respectively.
- Get rid of interfering light or reflections so that no other peaks are visible.
- Improve the alignment further until the ratio between the peaks and the background is greater than 5:1 for both sliders.

Connecting the holding magnet:

- Remove the second slider.
- Switch the air supply on, and optimise the air flow.
- Equip the slider with the holding plate and move it to the holding magnet.

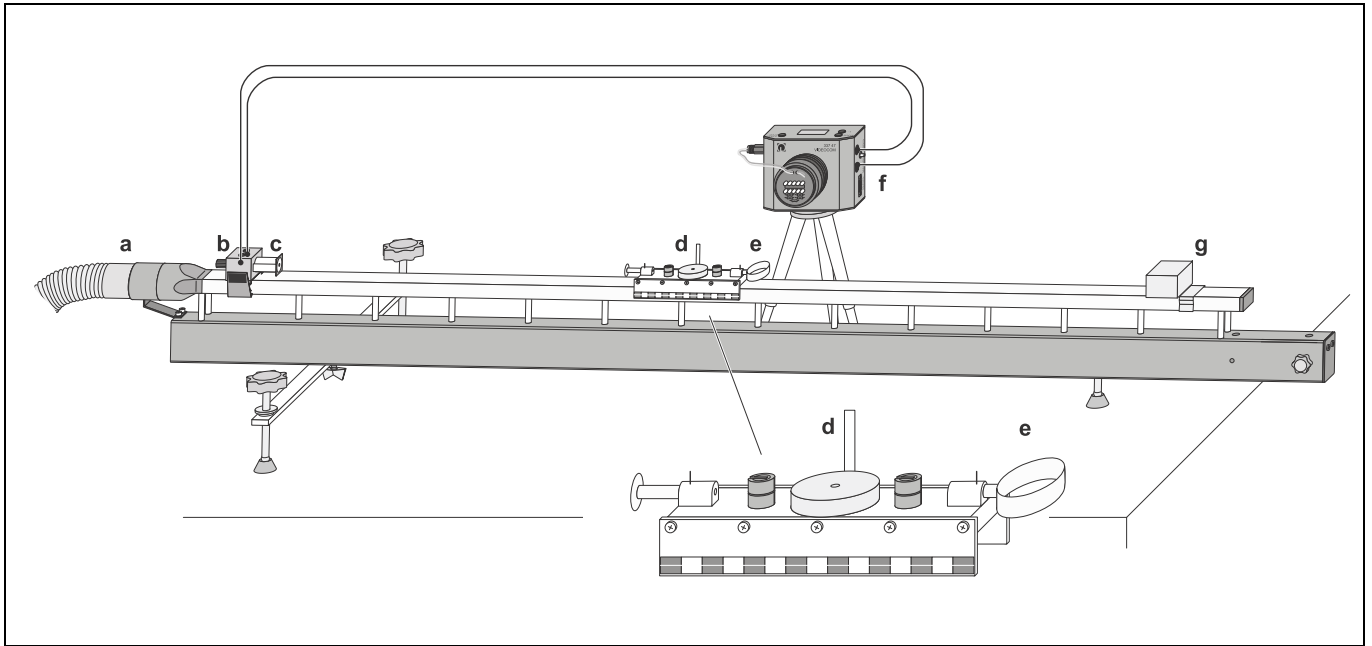





Fig. 2 Experimental setup for recording motion with VideoCom.

- Set the supply voltage for the holding magnet to its maximum value with the adjusting pin (f) at the VideoCom housing.
- Adjust the iron core of the holding magnet with the knurled screw (b) so that the slider is just kept and starts running immediately after pressing the key START at the VideoCom housing.
- Delete the old measured values with the button  or the key F4, record the motion of the slider, and determine the angle α anew.
- Repeat the procedure until $\alpha = 0^\circ$ is displayed; then activate "Use Linearisation" and take on the displayed distortion δ .

Compensating the distortion:

- Change to the representation "Path" in the program "VideoCom Motions".
- Equip the slider with both interrupter flags (distance = 5 cm).
- Call the menu "Settings/Path Calibration" with the button  or the key F5.
- Enter the values 0 m and 0.05 m as positions of the two interrupter flags in the register "Path Calibration".
- Click the button "Read Pixels From Display" and activate "Use Calibration".
- Call the menu "Settings/Path Calibration" anew and enter the following settings in the register "Setpoint Selection".

Δt	100 ms (10 fps)
Flash	Auto
Smoothing	Standard (4*dt)
Stop measurement	after covering the path
s	e.g. 0.9 m

- Start the measurement with the button  or the key F9, and record the motion of the slider.
- Next click the button "Suggest Linearisation" in the register "Linearisation" of the menu "Settings/Path Calibration".
- If an angle $\alpha \neq 0^\circ$ is displayed, the angle between the linear air track and VideoCom is not yet correct (see Fig. 3):
- Reject the linearisation with the button "Interrupt".
- Adjust the position of the linear air track by displacing the "right foot".



Path calibration:

- Equip both sliders with interrupter flags once more, move the first slider to the holding magnet, and put the second slider on the linear air track while the air supply is switched off so that the distance between the two interrupter flags is exactly 1 m.
- Enter the values 0 m and 1 m as positions of the two sliders in the register "Path Calibration" of the menu "Settings/Path Calibration".
- Click the button "Read Pixels From Display", and activate "Use Calibration".

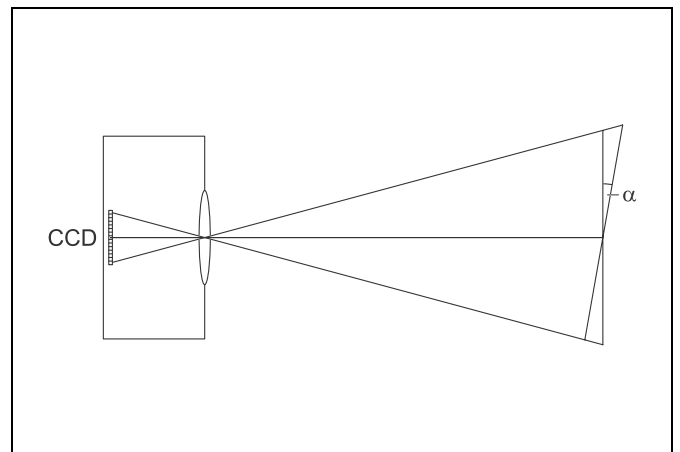
Fig. 3 Scheme of the definition of the angle α between the linear air track and VideoCom.



Carrying out the experiment

- Equip the slider with the impact spring (e), and attach four 1 g weights and one 100 g weight so that the total mass m of the slider is 200 g (see instruction sheet of linear air track).
- Put the massive block on the air track and fix it with the brake so that the slider is reflected elastically after a path of 1 m from the holding magnet.
- Call the menu "Settings/Path Calibration" with the button  or the key F5.
- Choose, e.g. "Stop measurement after set time $t = 16$ s" in the register "Settings".
The slider should reach the upper reversal point at least two times within the chosen time t .
- Delete old measured values with  or F4, move the slider to the holding magnet, start the measurement, and record the path-time diagram.
- Store the measurement with  or F2 (use a filename that allows you to recognise the file).

Measuring example and evaluation

a) Path

Fig. 4 shows the path-time diagram of the slider recorded with VideoCom. The direction of motion was reversed three times, two reversals being due to reflection at the massive obstacle (at $s_0 = 1$ m).

After the first reflection the slider almost reaches its starting point $s = 0$ (energy conservation). There is a small energy loss due to friction of the slider.

Between two reflections the path-time diagram is – in accordance with Eq. (VI) – a parabola. Proof:

- Click the diagram window with the right mouse key, choose "Fit Function" → "Parabola", and mark the desired range to be fitted with left mouse key.

Fig. 4 Path-time diagram of the uniformly accelerated motion with reversal of the direction, recorded with VideoCom.

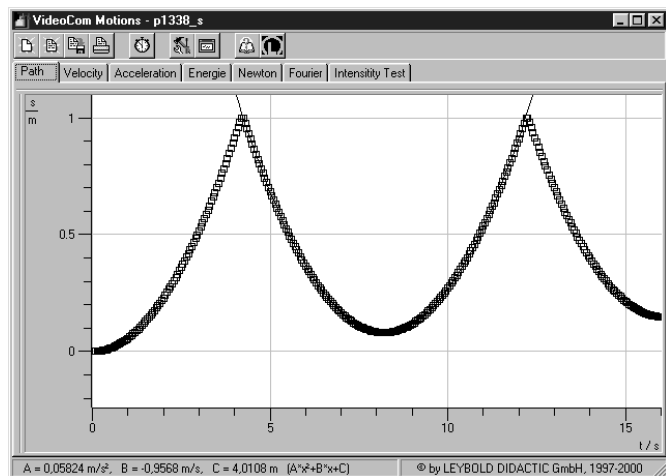

b) Velocity

Fig. 5 shows the velocity-time diagram of the slider, which is computed after clicking the register "Velocity". The two reflections at the massive obstacle are discerned as sudden changes of the sign. Before reflection, the path $\Delta s = s_2 - s_1$ covered in the time interval Δt is positive, and the velocity

$$v = \frac{\Delta s}{\Delta t} > 0.$$

After reflection, the path Δs is negative, and the velocity

$$v = \frac{\Delta s}{\Delta t} < 0.$$

Thus changes of the direction of motion correspond to a change of sign of the velocity. When the velocity passes through zero, the tangent of the path-time diagram becomes horizontal.

Between the reversal points, the velocity-time curve is – in accordance with Eq. (V) – linear. Proof:

- Click the diagram window with the right mouse key, choose "Fit Function" → "Best-fit straight line", and mark the desired range to be fitted with left mouse key.

Fig. 5 Velocity-time diagram corresponding to Fig. 4

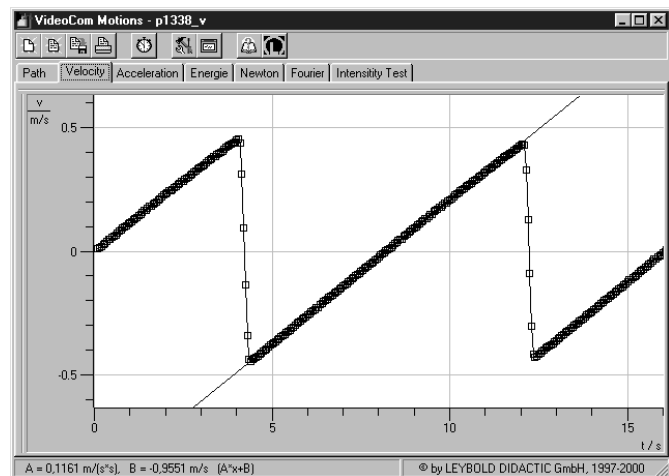

Acceleration

Fig. 6 shows the acceleration-time diagram of the slider, which is computed after clicking the register "Acceleration". The acceleration is constant while the slider moves downhill and uphill, the sign remaining the same during the entire process because the change in velocity $\Delta v = v_2 - v_1$ in a time interval Δt is always positive.

During reflection, the acceleration assumes large negative values. While the slider approaches the massive block, it is quickly slowed down to $v = 0$ through deformation of the impact spring and then quickly accelerated in the negative direction of motion through relaxation of the spring. At $v = 0$, the impact spring is maximally loaded.

Determination of the acceleration a :

- Click the diagram window with the right mouse key, choose "Draw Mean Value", and mark the desired range to be fitted between two reflections with the left mouse key.
- Take the value of the acceleration a down.

Total energy

- Call the menu "Settings/Path Calibration" with the button  or the key F5.
- Click the register "Formula" and make, e.g., the following entries:

Quantity: Energy
 Symbol: E
 Unit: mJ
 Minimum: -1 (mJ)
 Maximum: 25 (mJ)
 Formulas: $0.5 \cdot 200 \cdot v_1^2 + 200 \cdot 0.115 \cdot (1.0 - s_1)$

200: mass of the slider in g,
 1.0: distance from the place of reflection in m
 0.115: mean value of the acceleration in $m \cdot s^{-2}$

- Confirm the entries with the button "OK", and click the new register "Energy".

Fig. 7 shows the total energy of the slider as a function of time. The energy is not really constant, but it decreases in the course of time because of frictional losses. These frictional losses are greatest immediately before and after reflection because then the velocity of the slider attains its maximum value.

During the process of reflection the impact spring absorbs energy and then transfers it almost completely back to the slider.

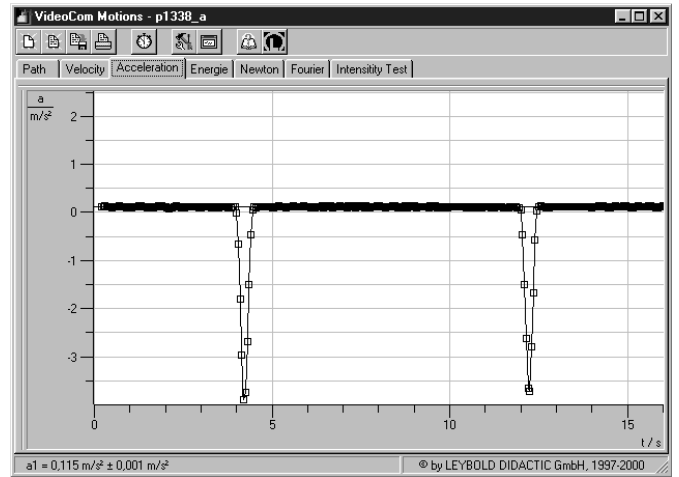

Fig. 6 Acceleration-time diagram corresponding to Fig. 4

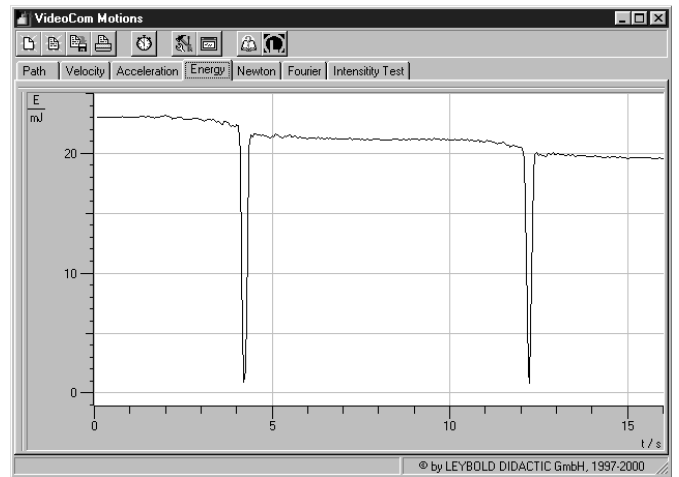

Fig. 7 Energy-time diagram corresponding to Fig. 4

