

Static friction, sliding friction and rolling friction

Objects of the experiment

- Investigating the static and sliding friction as a function of the area, the weight and the material
- Comparison of static and sliding friction as a function of the weight and determining the coefficient of friction
- Comparison of rolling and sliding friction as a function of the weight and determining the coefficient of friction

Principles

In discussing friction between solid bodies, we distinguish between static friction, sliding friction and rolling friction. Static friction force is the minimum force required to set a body at rest on a solid base in motion. Analogously, dynamic (kinetic), or sliding friction force is the force required to maintain a uniform motion of the body. Rolling friction force is the force which maintains the uniform motion of a body which rolls on another body.

To begin, this experiment verifies that the static friction force F_H and the sliding friction force F_G are independent of the size of the contact surface and proportional to the resting force G on the base surface of the friction block. Thus we can say:

$$F_H = \mu_H \cdot G \quad (I)$$

and

$$F_G = \mu_G \cdot G \quad (II).$$

The coefficients of friction μ_H and μ_G depend on the material of the contact surfaces. As the static friction force is always greater than the sliding friction force, we can always say

$$\mu_H > \mu_G \quad (III).$$

To distinguish between sliding and rolling friction, the friction block is placed on top of multiple stand rods laid parallel to each other. The rolling friction force

$$F_R = \mu_R \cdot G \quad (IV)$$

is measured as the force which maintains the friction block in a uniform motion on the rolling rods. The sliding friction force F_G is measured once more for comparison, whereby this time the friction block is pulled over the stand rods arranged as a fixed base. The experiment confirms the relationship

$$\mu_G > \mu_R \quad (V).$$

Setup

- Prepare clean, dry and smooth experiment surfaces (e.g. laboratory bench) for the friction experiments.
- If the resulting frictional forces are too slight, use different base surfaces.

Carrying out the experiment

- Using the dynamometer, determine the weight (force of gravity) G_1 of the large wooden block and G_2 for the small block.

a) Static and sliding friction as a function of the area, the weight and the material

- Place the small block on the experiment surface with the plastic side down.
- Using the dynamometer, measure the maximum horizontal pulling force at which the body remains stationary on the experiment surface as the static friction force F_H .
- Measure the horizontal pulling force which maintains a uniform motion on the experiment surface as the sliding friction force F_G .
- Place the wooden block on the base surface with the wide wooden side and then the narrow wooden side down and repeat your measurements for F_H and F_G .
- Repeat the measurements with the large block for friction experiments.
- Repeat the measurement on other surfaces as desired.

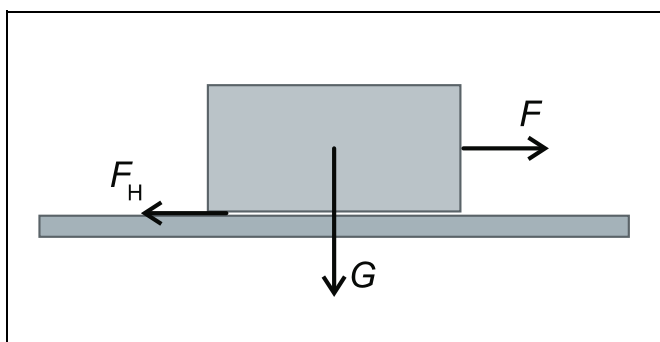

Apparatus

1 Pair of wooden blocks for friction experiments	342 10
1 Set 7 weights, 0.1 – 2 kg, with hook	315 36
1 Dynamometer, 10.0 N	314 47
6 Stand rods 10 cm	300 40

b) Static and sliding friction force as a function of the force of gravity

- Place the large block on the experiment surface with the plastic side down and measure the static and sliding friction force.
- Increase the weight of the block by adding in turn the weights 0.1 kg, 0.2 kg, 0.5 kg and 1.0 kg and repeat the measurements.
- Carry out the same measurements for the wooden side of the block as well.

c) Rolling and sliding friction force as a function of the force of gravity

- Lay the stand rods next to each other and place the large block on the rods with the plastic side down.
- Measure the horizontal pulling force which maintains a uniform motion on the rolling rods as the rolling friction force F_R .
- Increase the weight of the block by adding in turn the weights 0.1 kg, 0.2 kg, 0.5 kg and 1.0 kg and repeat the measurements.
- Align the block parallel to the rod axes and measure the sliding friction force.

Measuring example

$G_1 = 1.5 \text{ N}$

$G_2 = 3.0 \text{ N}$

a) Static and sliding friction as a function of the area, the weight and the material

Experiment surface: plastic-coated benchtop

Tab. 1: Static friction force F_H and sliding friction force F_G as a function of the force of the aerea, the weight and the material

$\frac{G}{N}$	Material	$\frac{A}{\text{cm}^2}$	$\frac{F_H}{N}$	$\frac{F_G}{N}$
1.5	Plastic	12×6	0.8	0.6
1.5	Wood	12×6	0.3	0.3
1.5	Wood	12×3	0.3	0.3
3.0	Plastic	12×6	1.6	1.1
3.0	Wood	12×6	0.5	0.5

b) Comparison of static and sliding friction force

Experiment surface: plastic-coated benchtop

Table 2: Static friction force F_H and sliding friction force F_G as a function of the force of gravity G

$\frac{G}{N}$	Plastic side		Wooden side	
	$\frac{F_H}{N}$	$\frac{F_G}{N}$	$\frac{F_H}{N}$	$\frac{F_G}{N}$
3	1.6	1.1	0.5	0.4
4	2.2	2.0	0.8	0.6
5	3.1	2.8	0.9	0.8
8	5.0	4.6	1.9	1.3
13	8.3	8.0	3.0	2.0

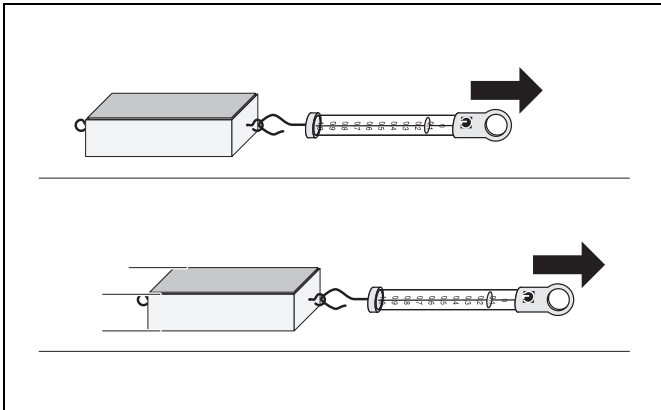

Fig. 1 Measuring the static friction force F_H (top) and the sliding friction force F_G (bottom).

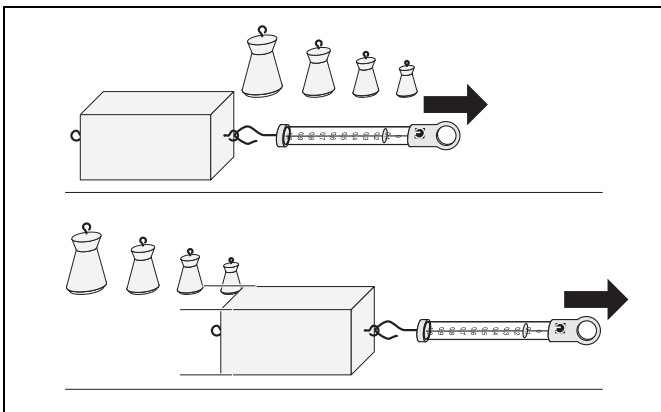

Fig. 2 Measuring the static friction force F_H (top) and the sliding friction force F_G (bottom) as a function of the force of gravity G .

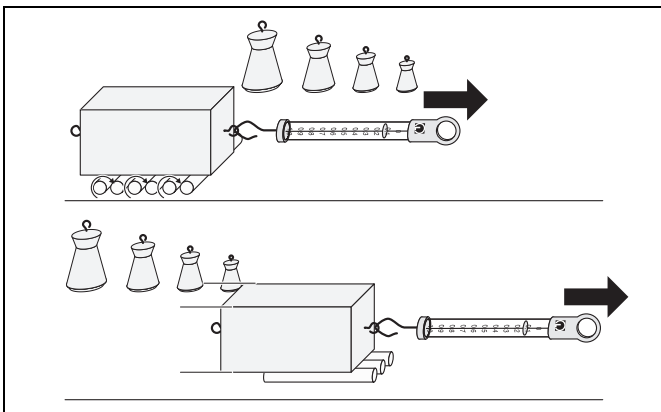

Fig. 3 Measuring the rolling friction force F_R (top) and the sliding friction force F_G (bottom) as a function of the force of gravity G .

c) Comparison of sliding and rolling friction

Table 3: Sliding friction force F_G and rolling friction force F_R as a function of the force of gravity G

$\frac{G}{N}$	$\frac{F_G}{N}$	$\frac{F_R}{N}$
3	3.0	0.1
4	4.3	0.2
5	5.2	0.2
8	9.0	0.3
11		0.4
13		0.5
18		0.6
23		0.7

Fig. 4 shows the results of the measurements. The slope of the line through the origin is equivalent to the coefficients of friction μ_H and μ_G calculated using (I) and (II) (see Table 2).

Table 4: Static friction coefficient μ_H and sliding friction coefficient μ_G for friction on plastic

Material	μ_H	μ_G
Plastic	0.63	0.59
Wood	0.22	0.15

Evaluation and results

a) Static and sliding friction as a function of the area, the weight and the material

As the measuring results in Table 1 show, both the static friction force and the sliding friction force depend on the material properties of the friction surfaces and on the weight (force of gravity) of the blocks. However, the friction forces are independent of the size of the friction area.

b) Comparison of static and sliding friction force

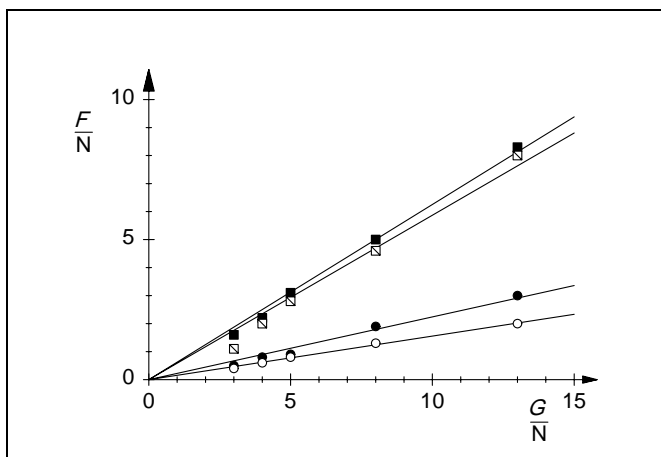

Fig. 4 Static friction force F_H and sliding friction force F_G as a function of the force of gravity G

- Closed squares: static friction for plastic
- Open squares: sliding friction for plastic
- Closed circles: static friction for wood
- Open circles: sliding friction for wood
- Experiment surface: plastic-coated benchtop

c) Comparison of sliding and rolling friction

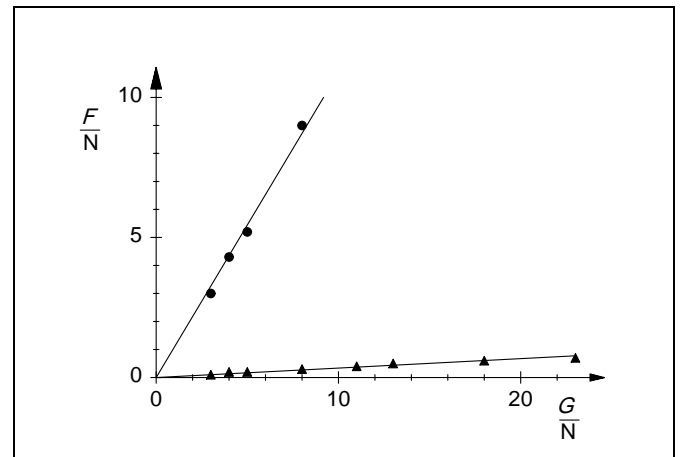

Fig. 5 Sliding friction force F_G (circles) and rolling friction force F_R (triangles) as a function of the force of gravity G

Fig. 5 shows the results of the measurements. The slope of the line through the origin is equivalent to the coefficients of friction μ_H and μ_G calculated using (I) and (II) (see Table 3).

Table 5: Rolling friction coefficient μ_R and sliding friction coefficient μ_G

Material:	μ_G	μ_R
Plastic	1.09	0.03

