

Using a spherometer to determine bending radii

Objects of the experiment

- Measuring the convexities (resp. concavities) h of watch glasses for a given distance between the stand points of the spherometer
- Calculating the bending radii R of the watch glasses
- Measuring the thickness d of a pile of glass plates

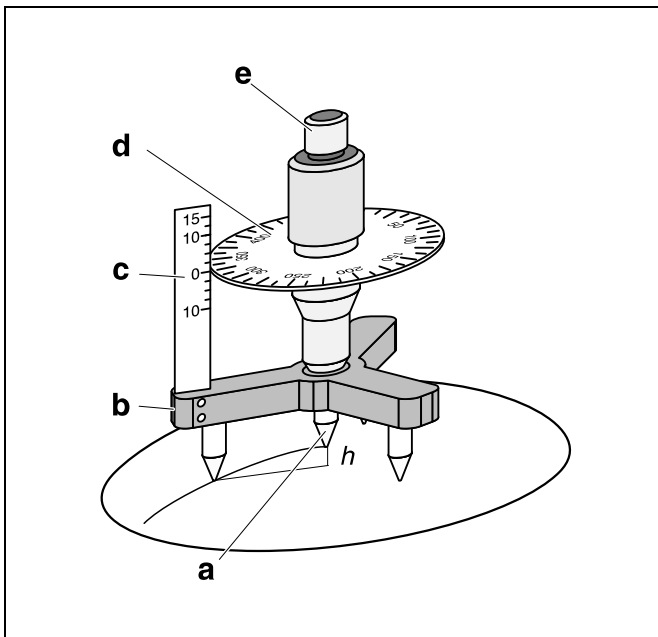

Principles

The spherometer consists of a tripod with three steel points as feet which form an equilateral triangle with a length of 50 mm on each side (see Fig. 1). A micrometer screw with measuring point is mounted through the center of the tripod. A vertical scale indicates the height h of the measuring point above the level defined by the tripod points. The shift of the measuring point can be read off to an accuracy of $1\ \mu\text{m}$ using the scale of the disk which turns with the micrometer screw.

The relationship:

$$R^2 = r^2 + (R - h)^2$$

exists between the distance r of the stand points from the center of the spherometer, the bending radius R to be found and the convexity h (see Fig. 2).

From this, we derive the equation for determining R :

$$R = \frac{r^2}{2h} + \frac{h}{2} \quad (1)$$

The distance r is 29.0 mm, with a tolerance of 0.2 mm.

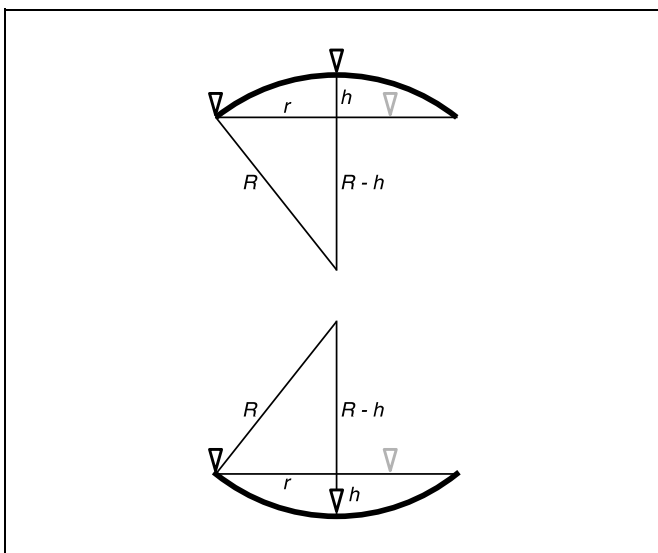

Fig. 1 Measuring the bending radius of a watch glass using a spherometer

- a Measuring point
- b Tripod with stand points
- c Vertical scale
- d Disk with scale
- e Micrometer screw

Fig. 2 Schematic vertical section through the measuring arrangement

- top: Measuring object with convex surface
- bottom: Measuring object with concave surface

Apparatus

1 Spherometer	311 86
1 Glass mirror, 115×100 mm	460 291
1 Cover slips for microscopy, set of 10	662 092
1 Watch glass dish, 80 mm dia.	664 154
1 Watch glass dish, 125 mm dia.	664 157

Carrying out the experiment

a) Measuring the thickness of a stack of glass plates:

- Place the stack of cover slips on the glass mirror.
- Screw the measuring point up using the micrometer screw and place the spherometer over this stack on the glass mirror.
- Screw down the measuring point using the micrometer screw until the tip touches the stack on the glass mirror.
- Read off the thickness d of the stack and write this value in the experiment log.

b) Determining the bending radii of watch glasses:

- Lay the large watch glass on the glass mirror with the convex side upwards.
- Screw the measuring point up using the micrometer screw and place the spherometer over this watch glass.
- Screw down the measuring point using the micrometer screw until the tip touches the watch glass on the glass mirror.
- Read off the convexity h and write this value in the experiment log.
- Then place the watch glass on the mirror with the concave side up and repeat the measurement.
- Repeat these measurements for the small watch glass.

Setup

Notes:

We can recognize that the measuring point of the spherometer is touching the surface of the object to be measured when, while carefully turning the micrometer screw,

- a) the tripod turns as well (reproducibility 5 μm),
- b) a slight tilting play of the spherometer can be felt (reproducibility 2 μm).

Two turns of the disk are required for 1 mm of stroke of the measuring point:

The most effective check is to keep count of the turns of the disk.

Checking the zero point:

- Screw the measuring point up using the micrometer screw and place the spherometer on the glass mirror.
- Screw down the measuring point using the micrometer screw until the tip touches the surface of the glass mirror, and check the zero point.

If the measuring object or the glass mirror are dirty:

- Clean these using a lint-free cloth and water with dish soap added.

Measuring example and evaluation

a) Measuring the thickness of a stack of glass plates:

$d = 1.563 \pm 0.002 \text{ mm}$ (stack of 10 cover slips)

b) Determining the bending radii of watch glasses:

Table 1 lists the measured values for the convexity h . We can use these values to calculate the bending radius R to within an accuracy of $\pm 1.5 \text{ mm}$ according to equation (I). The accuracy is essentially determined by the manufacturing tolerance for the distance r .

Table 1: Convexity (resp. concavity) h and bending radius r of watch glasses

\emptyset	Curvature	$\frac{h}{\text{mm}}$	$\frac{R}{\text{mm}}$
125 mm	convex	3.588	115.4
	concave	3.696	111.9
80 mm	convex	3.688	112.2
	concave	3.794	109.0